

# Zoning Requirements Diagram

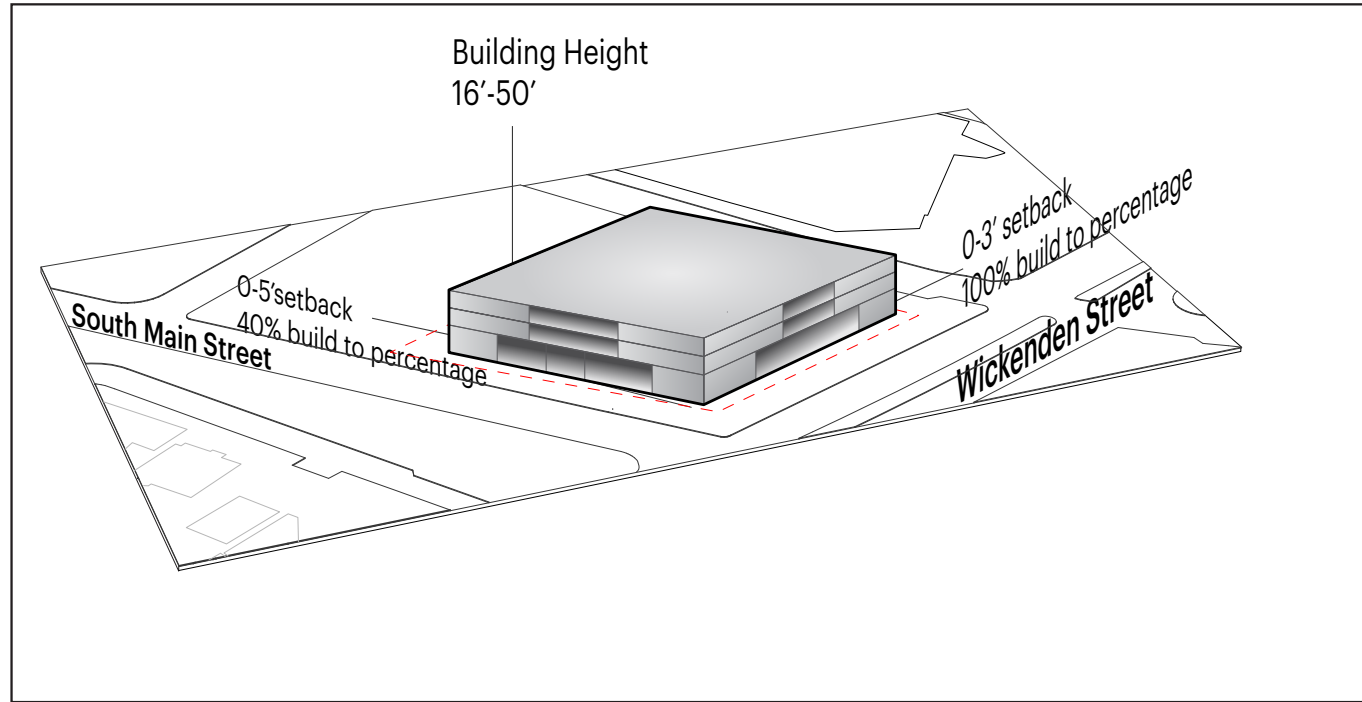

# Legend

	SECTION REFERENCE		DOOR NUMBER
	DETAIL REFERENCE		SPOT ELEVATION
	EXTERIOR ELEVATION		DATUM
	INTERIOR ELEVATION		NORTH ARROW
	CALLOUT REFERENCE		KEYNOTE
<b>Room name</b> 	ROOM NAME / NUMBER		MATERIAL KEYNOTE

# Drawing List Volume 1

General Drawings	
G000	Cover Sheet
G001.1	Egress Pathway Plan
G001.2	ADA Accessibility Route Plan
G002	Life Safety Plan
G003	Cost Comparison Analysis
G004A	Building Concepts   Pedestrian Circulation
G004B	Building Concepts   Flood Map
G004C	Building Concepts   Ventilation Analysis
G004D	Building Concepts   Daylight Autonomy
G004E	Building Concepts   Facade Design
G004F	Building Concepts   Harvesting Rainwater

Landscape Drawings	
L100	B2 Parking Plan
L101	B1 Parking Plan
L102	Site Plan

Architectural Drawings	
A100	Ground Floor Plan
A101	Upper Floor Plan
A102	Roof Plan
A200	Building Elevations
A201	Building Elevations
A202	Building Elevations
A203	Building Elevations
A300	Building Sections   Section A
A301	Building Sections   Section B
A302	Building Sections   Section C
A303	Building Sections   Section D
A400	Principle Wall Sections   Double Skin
A401	Principle Wall Sections   Glass Curtain Wall
A402	Principle Wall Sections   Brick Wall
A500	Vertical Circulation
A700	Interior Details
A701	Interior Details
A702	Interior Details

Structural Drawings	
S100	Framing Plan   Ground Floor
S101	Framing Plan   Upper Floors
S102	Structural Details

Mechanical Drawings	
M100	HVAC Drawings   Ground Floor
M101	HVAC Drawings   Upper Floors

Electrical Drawings	
E100	Ground Floor Plan
E101	Upper Floor Plan

Plumbing Drawings	
P100	Ground Floor Plan
P101	Upper Floor Plan
P102	Sprinkler Drawing

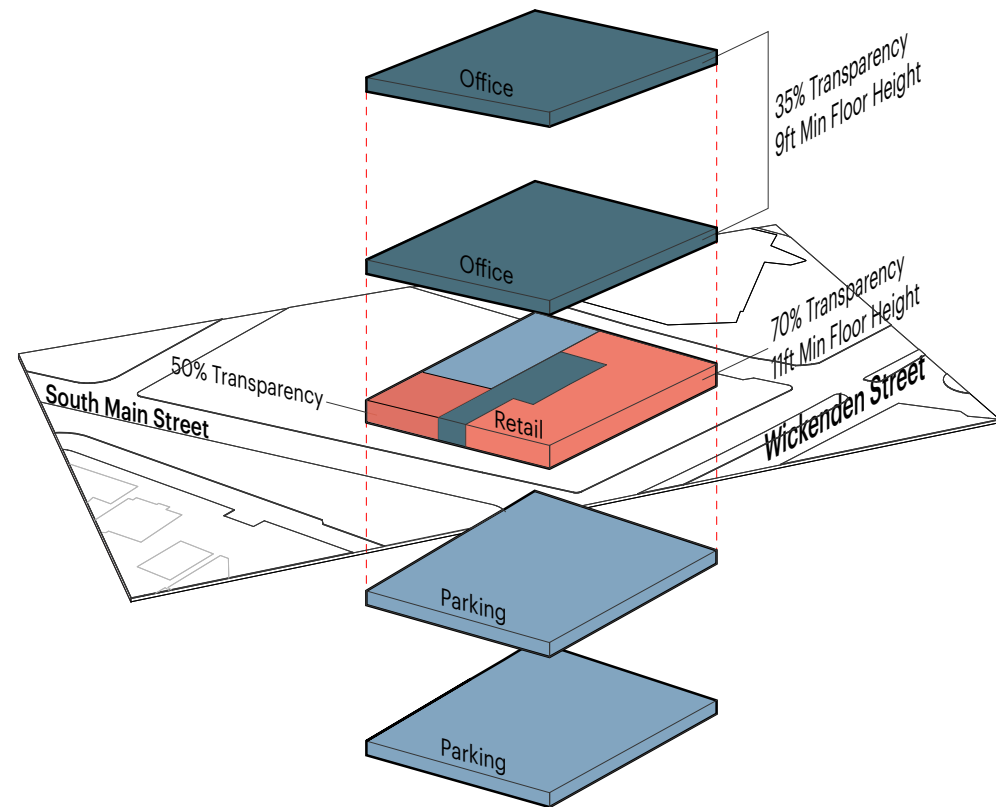

**2016 INTEGRATED BUILDING SYSTEMS  
ARCH 2178**  
Hyunbae Chang | Marco Didonet |  
Iris Kim | Jiseon Park | Natasha Ruiz

**FilterScape**  
Commercial Building  
117 Wickenden Street, Providence RI 02903

**GENERAL**  
Cover Sheet

**G000**

Egress Occupant Load	Area (sq ft)	Area/Occupant (gross)	Occupant Load
Lounge	3309	15	150
Commercial	10,974	200	50
Office	24,424	100	244
Parking	24,424	200	122
Mechanical	791	300	2

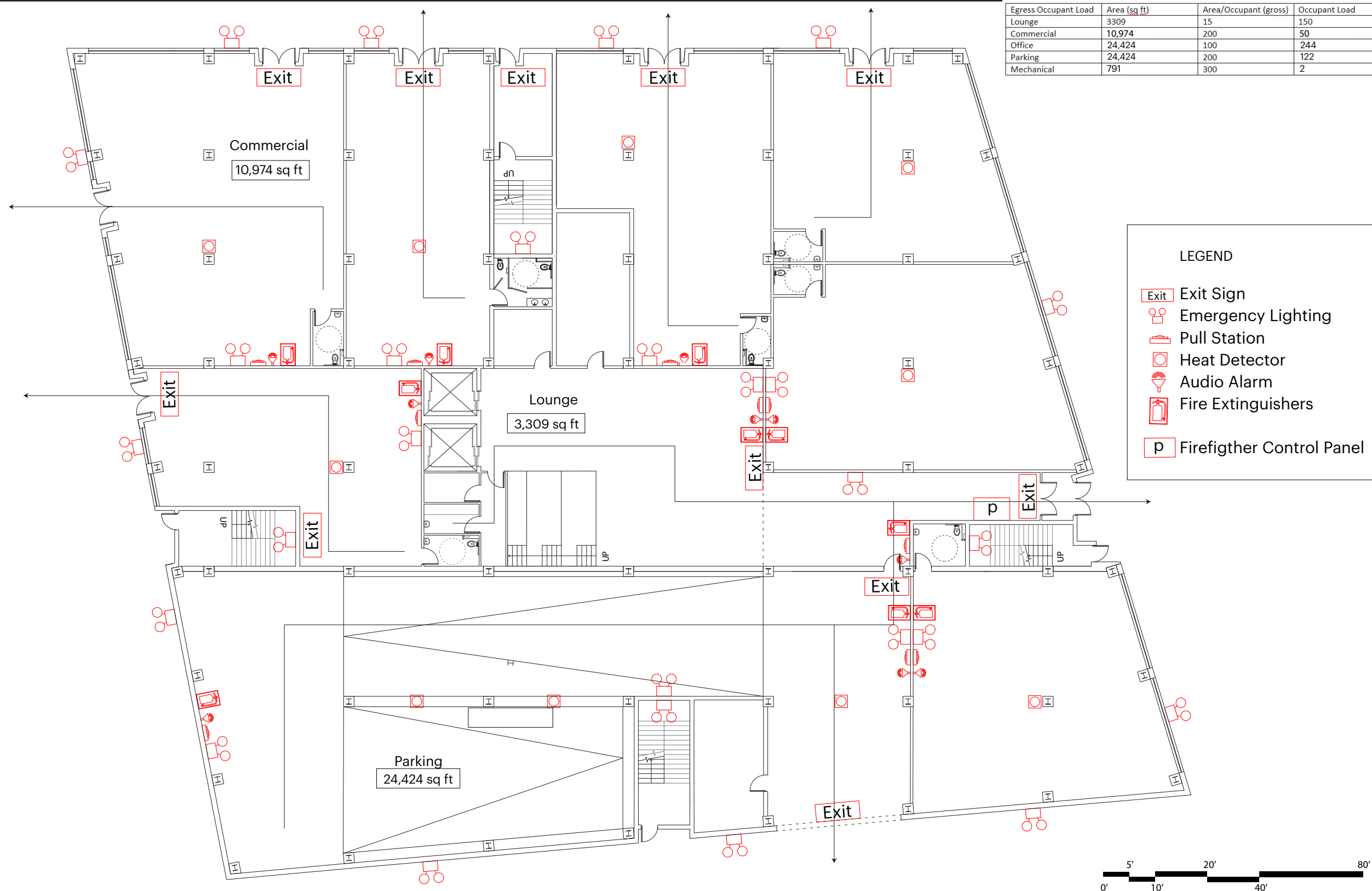

**2016 INTEGRATED BUILDING SYSTEMS**  
**ARCH 2178**  
 Hyunbae Chang | Marco Didonet |  
 Iris Kim | Jiseon Park | Natasha Ruiz

**FilterScape**  
**Commercial Building**  
 117 Wickenden Street, Providence RI 02903

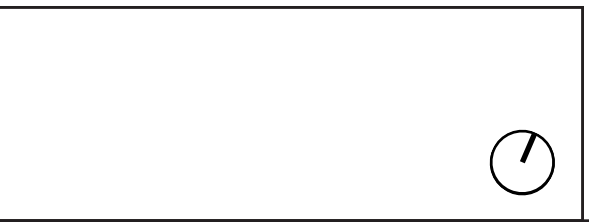

**GENERAL**  
 Life Safety Plan

**G002**



5000 NASA Blv



Lewis + Clark State Office Building



Preston Point

**Parcel 6, RI**

Type of Building  
Project Location  
Type of Work  
Cost Index

**Commercial Cost Estimate**

Retail Store  
Rhode Island-Providence  
Lump Sum  
High

Square Feet

Subtotal		<b>14,939,048.02</b>
Overhead	<input type="text" value="10.00%"/>	1,493,904.80
Profit	<input type="text" value="5.00%"/>	746,952.40
Bonding	<input type="text" value="1.00%"/>	149,390.48

Total Budget   
Per Square Foot

**5000 NASA Blv, WV**

-Office space  
-130,000 sqft  
-\$24million cost

\$184.61 per sqft

**Lewis + Clark state office building, MO**

-Office space  
-120,000 sqft  
-\$17million cost

\$141.66 per sqft

**Preston Pointe, KY**

-Commercial space  
-105,000 sqft  
-\$11.3million cost

\$107.61 per sqft



**2016 INTEGRATED BUILDING SYSTEMS**  
**ARCH 2178**  
 Hyunbae Chang | Marco Didonet |  
 Iris Kim | Jiseon Park | Natasha Ruiz

**FilterScape**  
 Commercial Building  
 117 Wickenden Street, Providence RI 02903



**GENERAL**  
 Building Concepts | Pedestrian  
 Circulation

**G004-A**

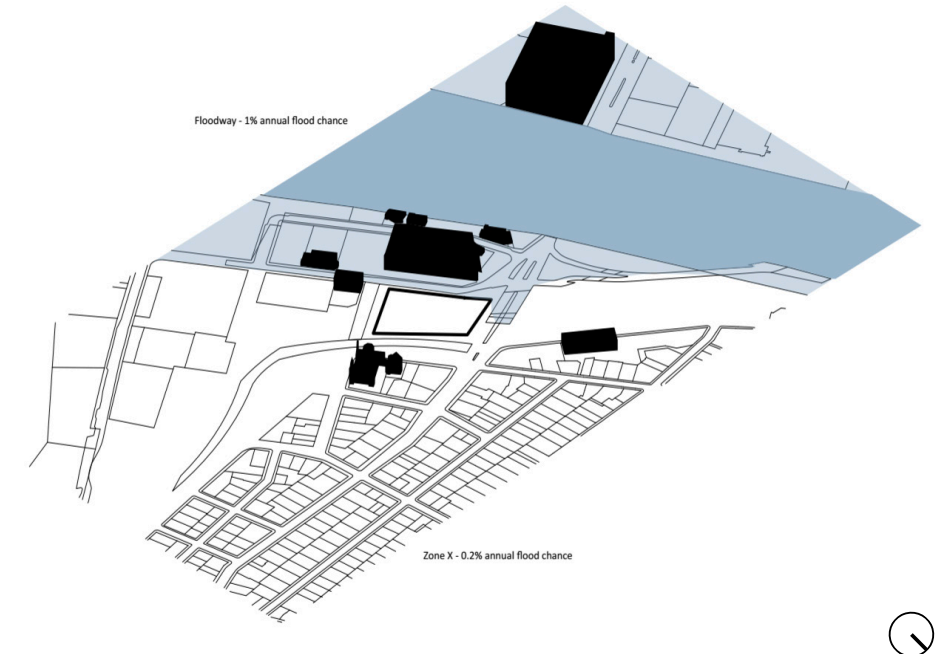

**2016 INTEGRATED BUILDING SYSTEMS**  
**ARCH 2178**  
 Hyunbae Chang | Marco Didonet |  
 Iris Kim | Jiseon Park | Natasha Ruiz

**FilterScape**  
**Commercial Building**  
 117 Wickenden Street, Providence RI 02903

**GENERAL**  
 Building Concepts | Flood Map

**G004-B**

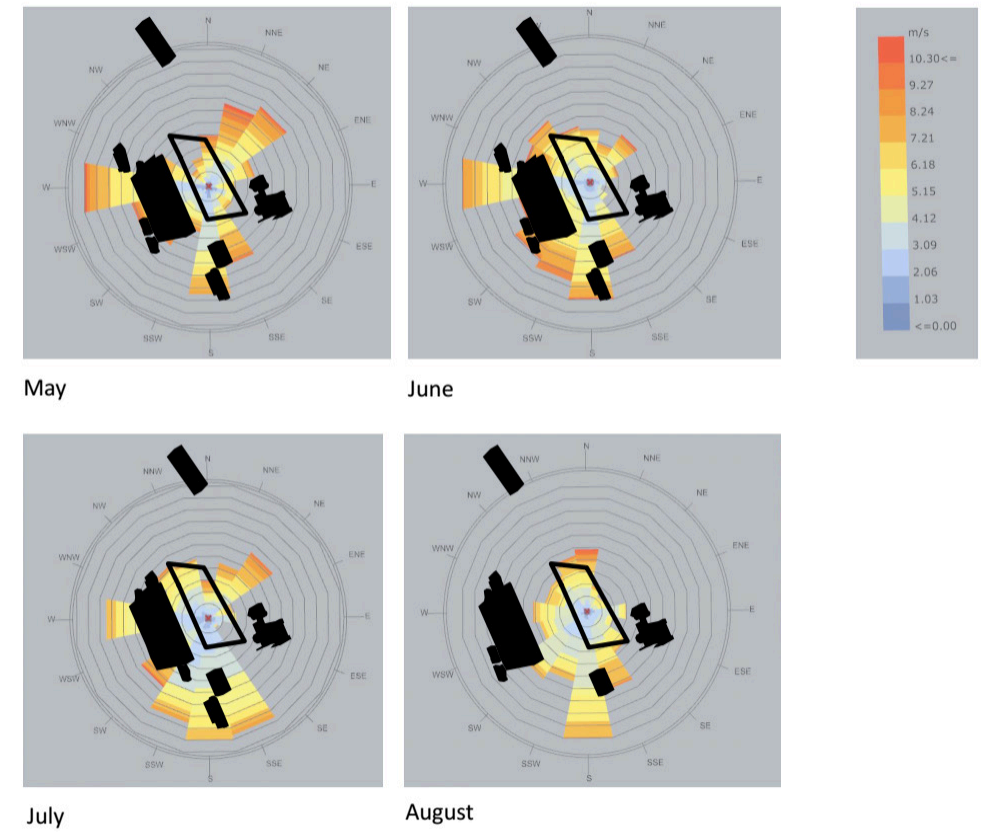
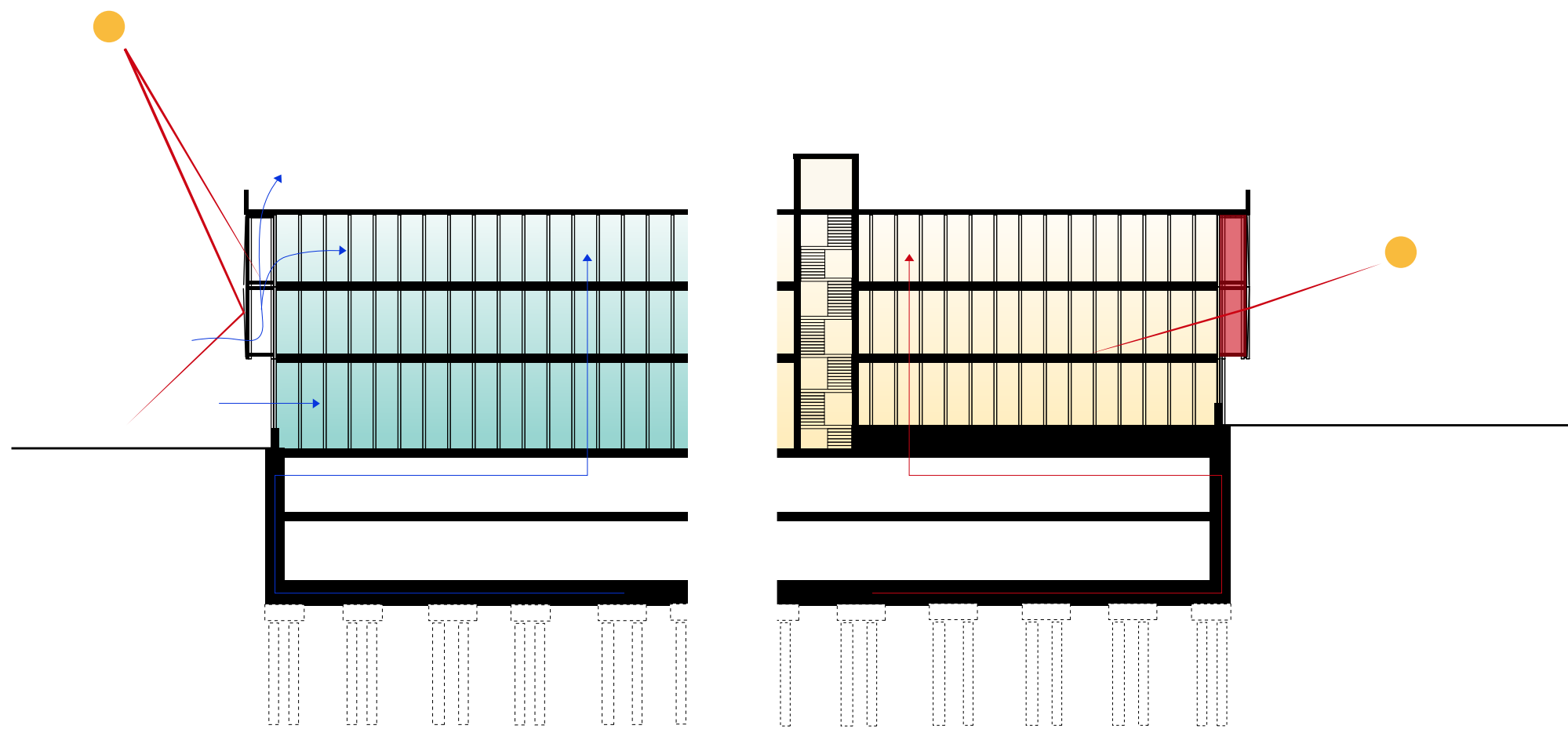
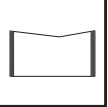

Overheating Hours during Cooling Season (July)

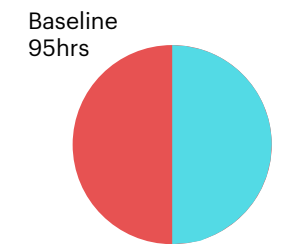

Overheating Hours during Cooling Season (July)

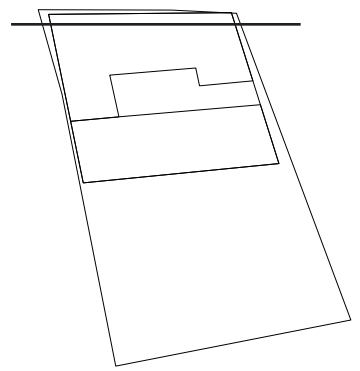
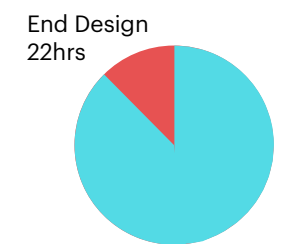

**2016 INTEGRATED BUILDING SYSTEMS**  
**ARCH 2178**  
 Hyunbae Chang | Marco Didonet |  
 Iris Kim | Jiseon Park | Natasha Ruiz

**FilterScape**  
 Commercial Building  
 117 Wickenden Street, Providence RI 02903



**GENERAL**  
 Building Concepts | Ventilation  
 Analysis

**G004-C**

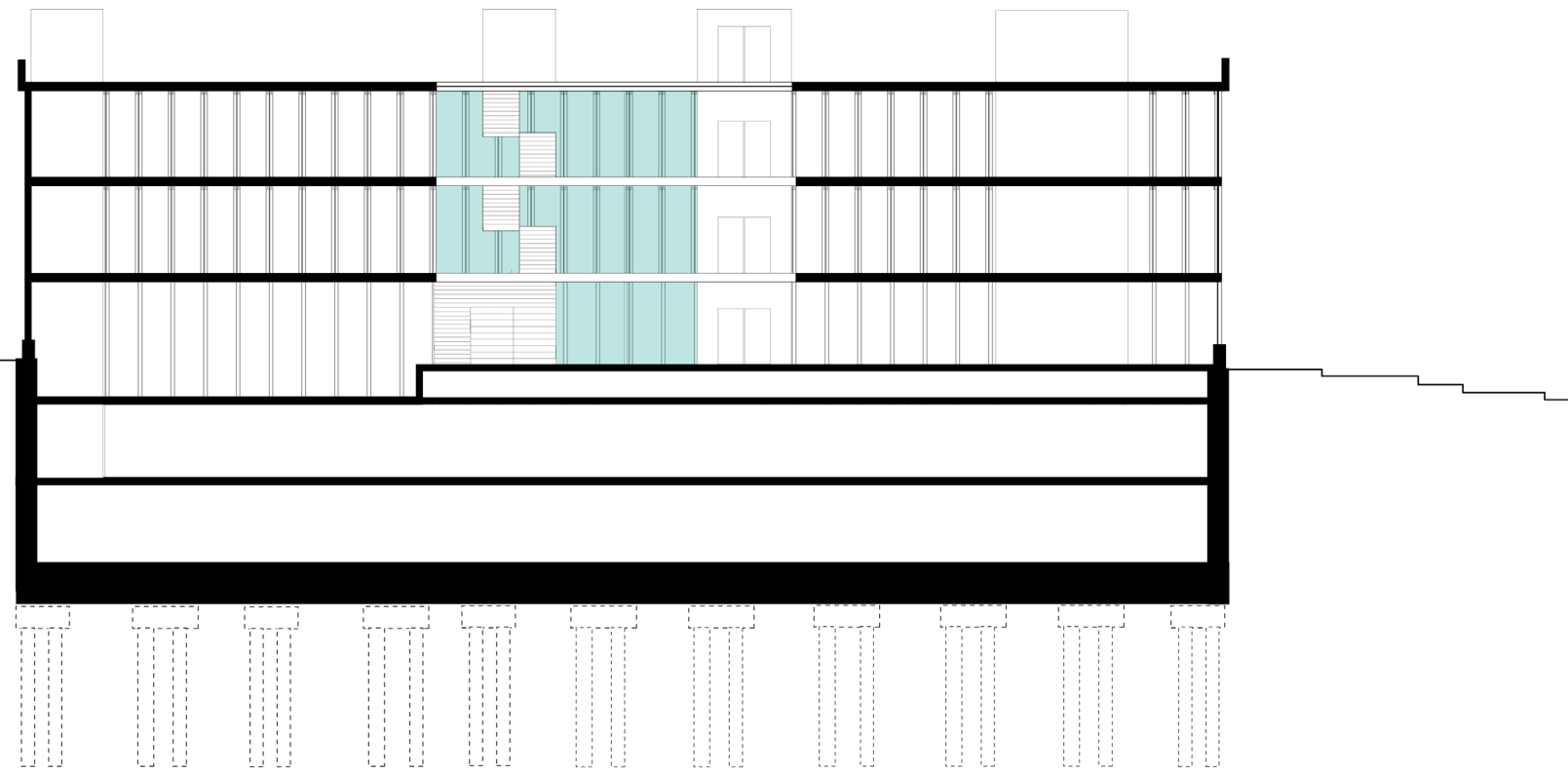
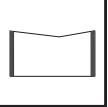

With Atrium  
**90% Daylit Area**

No Atrium  
**45% Daylit Area**

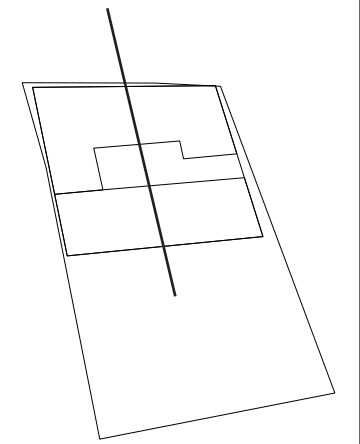
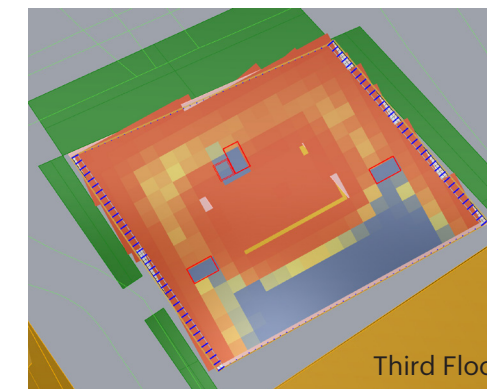
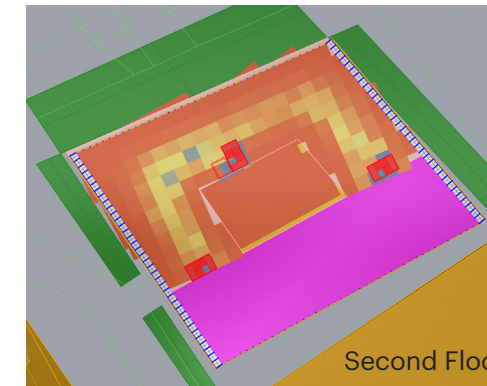
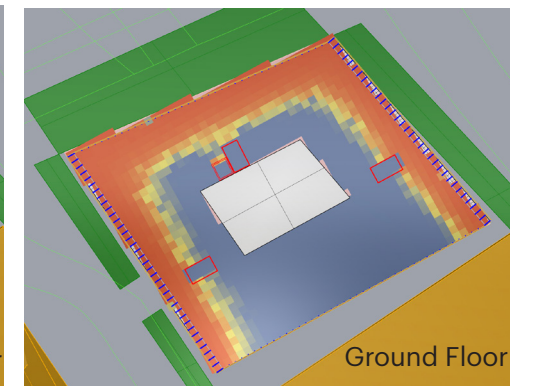
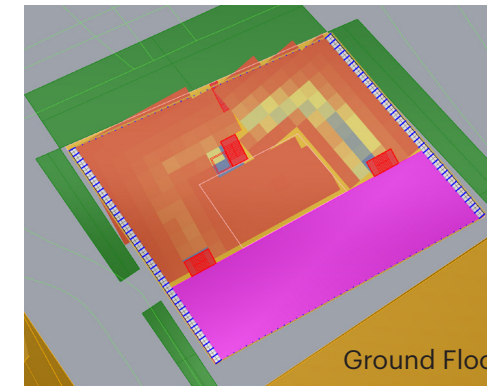

**2016 INTEGRATED BUILDING SYSTEMS**  
**ARCH 2178**  
Hyunbae Chang | Marco Didonet |  
Iris Kim | Jiseon Park | Natasha Ruiz

**FilterScape**  
**Commercial Building**  
117 Wickenden Street, Providence RI 02903

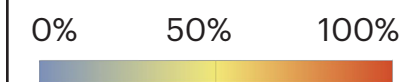

**GENERAL**  
Building Concepts | Daylight  
Autonomy

**G004-D**

Upper Levels Louver Density

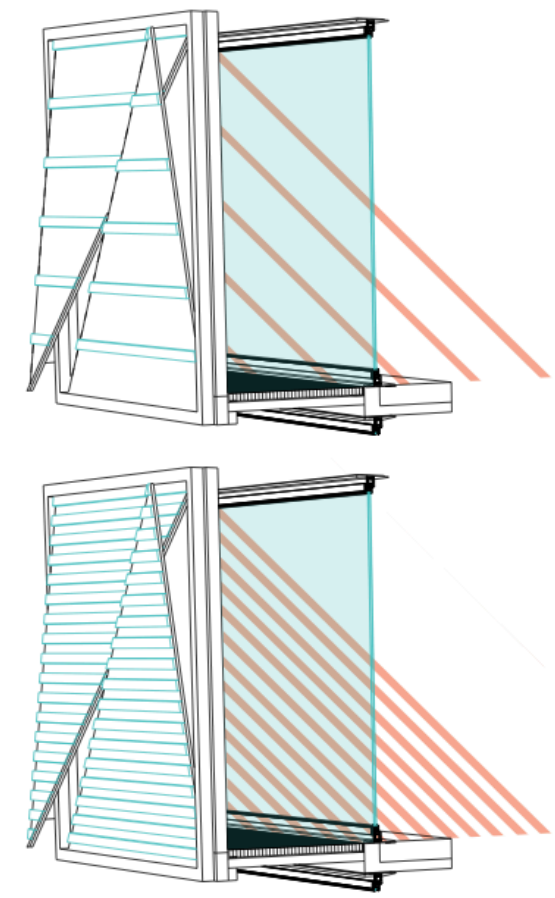
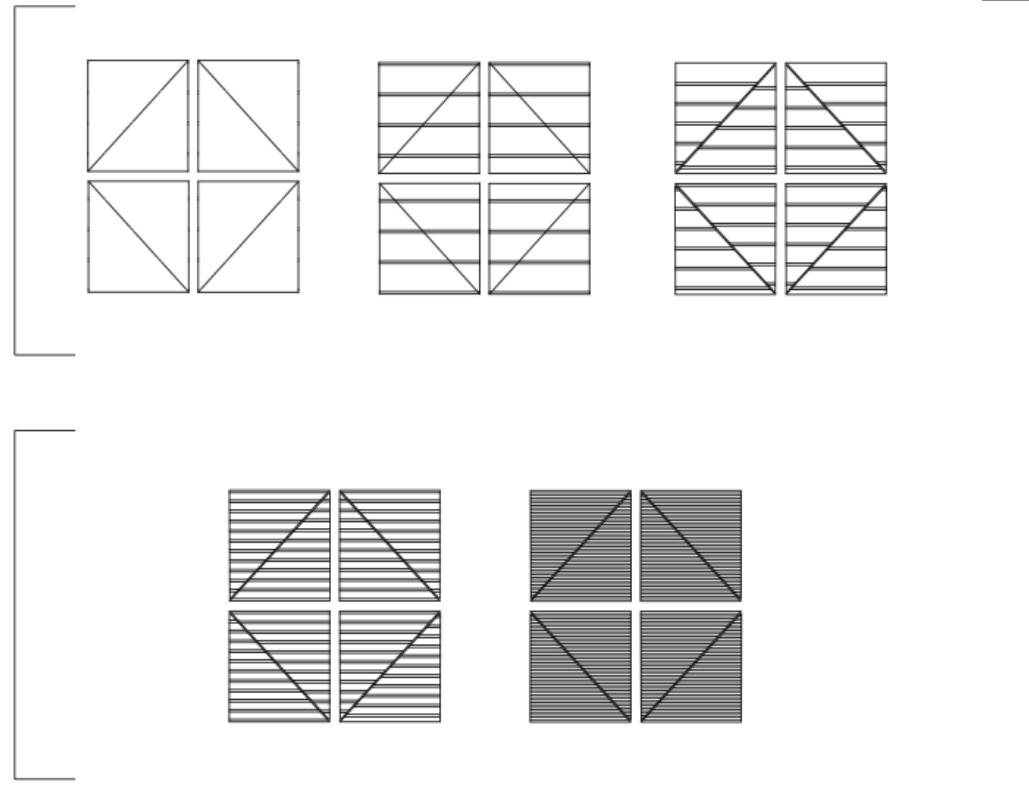

100% - 89%

75% - 50%

Ground Floor/ Brick Pattern

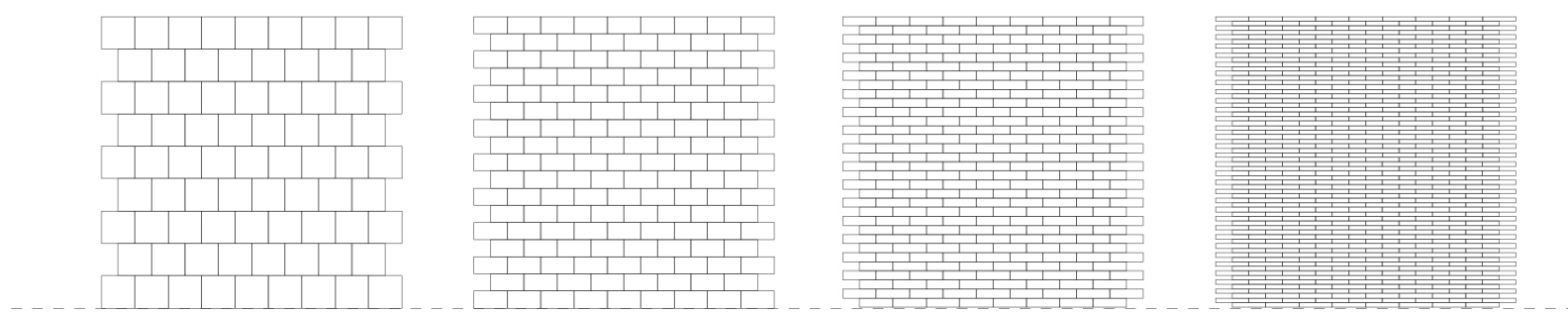

**2016 INTEGRATED BUILDING SYSTEMS**  
**ARCH 2178**  
 Hyunbae Chang | Marco Didonet |  
 Iris Kim | Jiseon Park | Natasha Ruiz

**FilterScape**  
**Commercial Building**  
 117 Wickenden Street, Providence RI 02903



**GENERAL**  
 Building Concepts | Facade Design  
**G004-E**



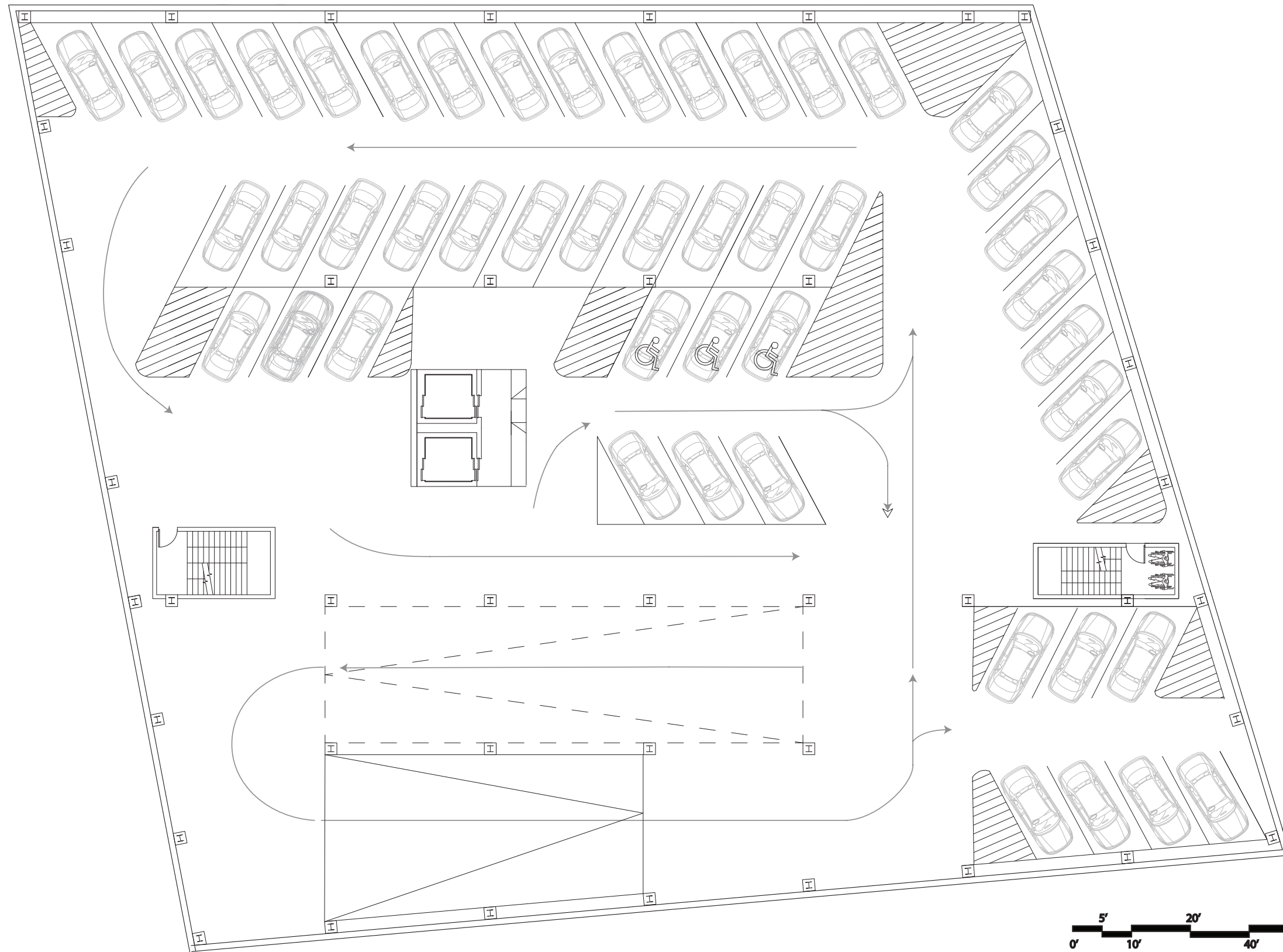

2016 INTEGRATED BUILDING SYSTEMS  
 ARCH 2178  
 Hyunbae Chang | Marco Didonet |  
 Iris Kim | Jiseon Park | Natasha Ruiz

**FilterScape**  
 Commercial Building  
 117 Wickenden Street, Providence RI 02903



LANDSCAPE  
 B2 Parking Plan

L100

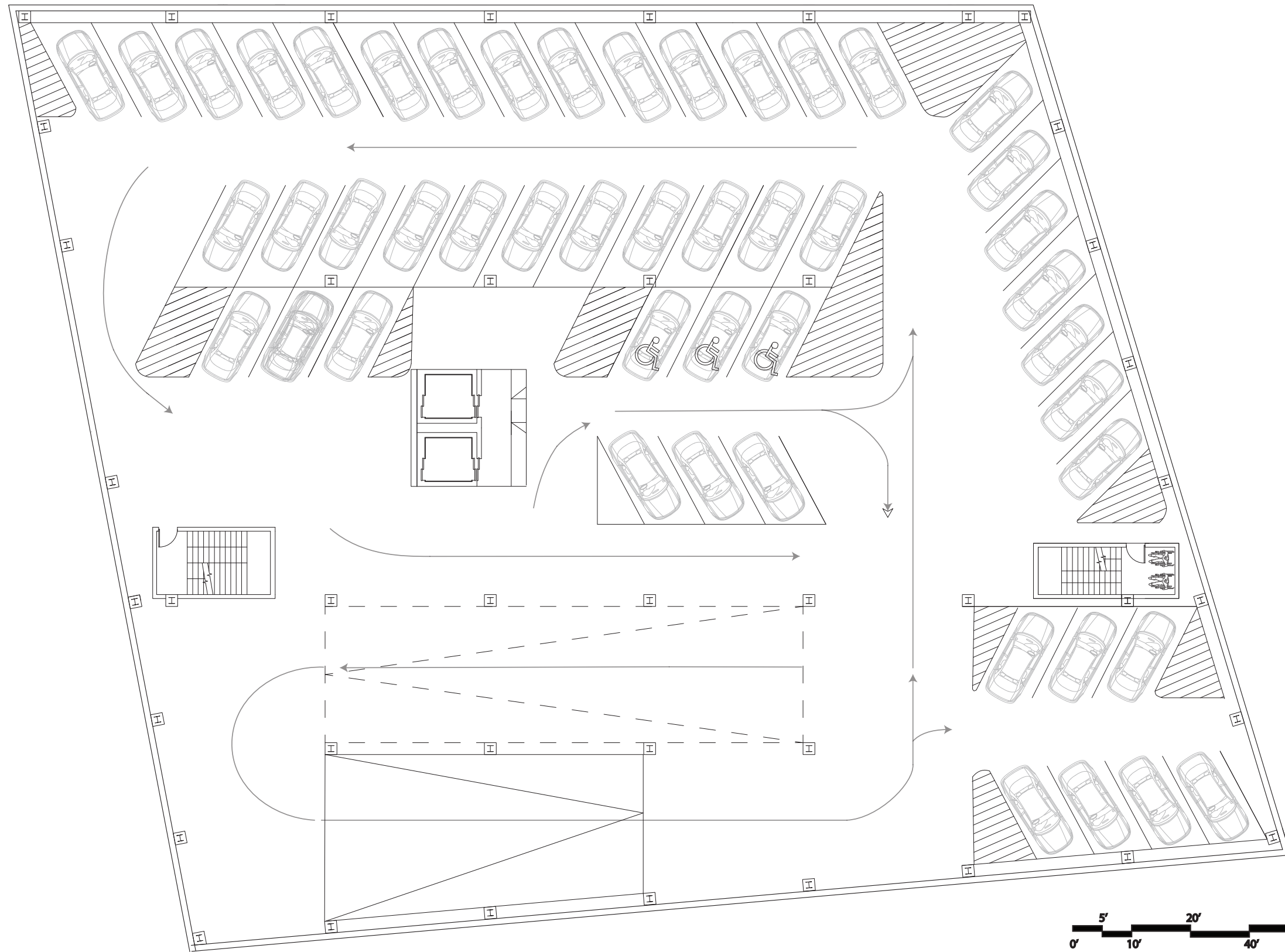

2016 INTEGRATED BUILDING SYSTEMS  
 ARCH 2178  
 Hyunbae Chang | Marco Didonet |  
 Iris Kim | Jiseon Park | Natasha Ruiz

**FilterScape**  
 Commercial Building  
 117 Wickenden Street, Providence RI 02903

LANDSCAPE  
 B1 Parking Plan



L101

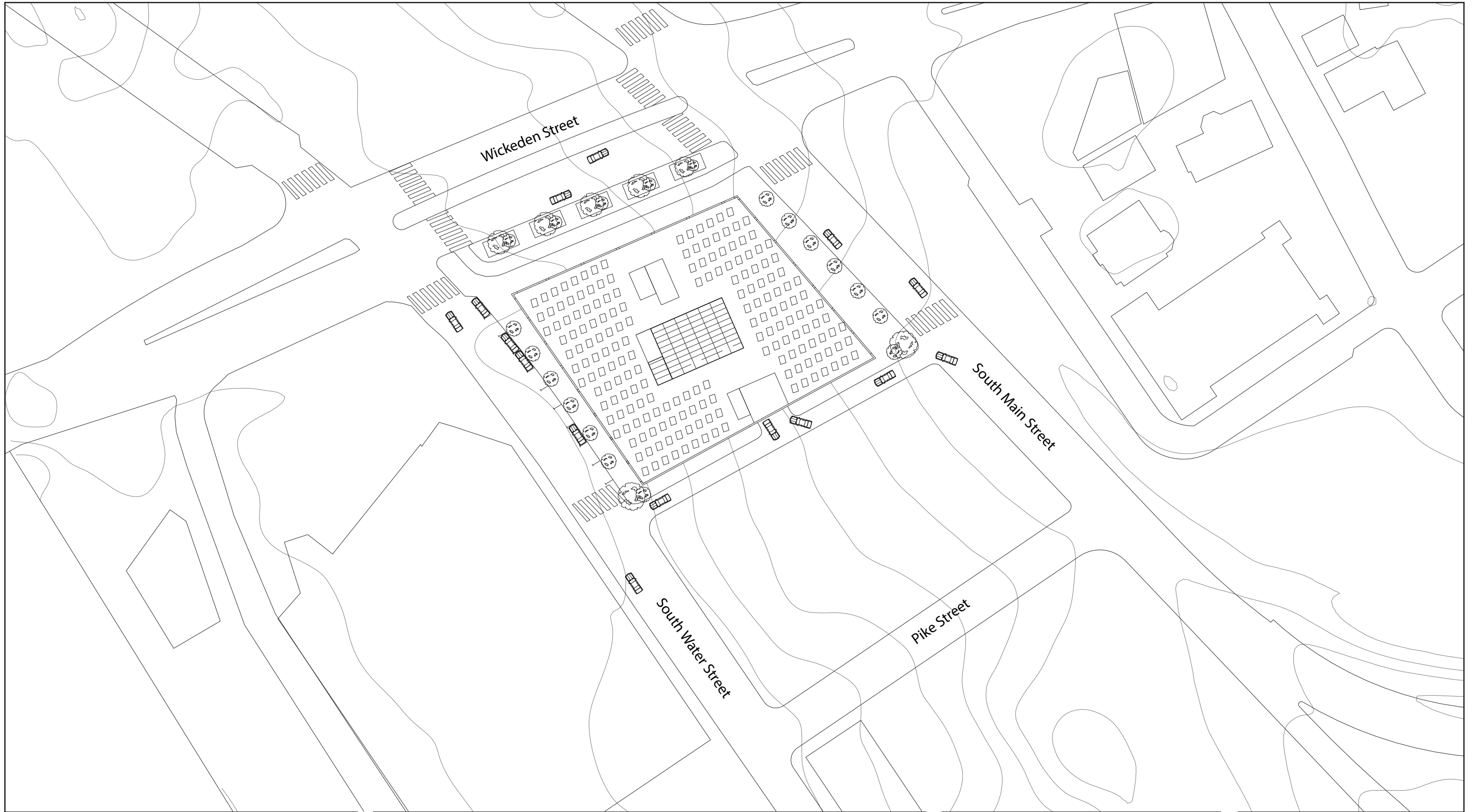

**2016 INTEGRATED BUILDING SYSTEMS**  
**ARCH 2178**  
Hyunbae Chang | Marco Didonet |  
Iris Kim | Jiseon Park | Natasha Ruiz

**FilterScape**  
**Commercial Building**  
117 Wickenden Street, Providence RI 02903



**LANDSCAPE**  
Site Plan

**L102**

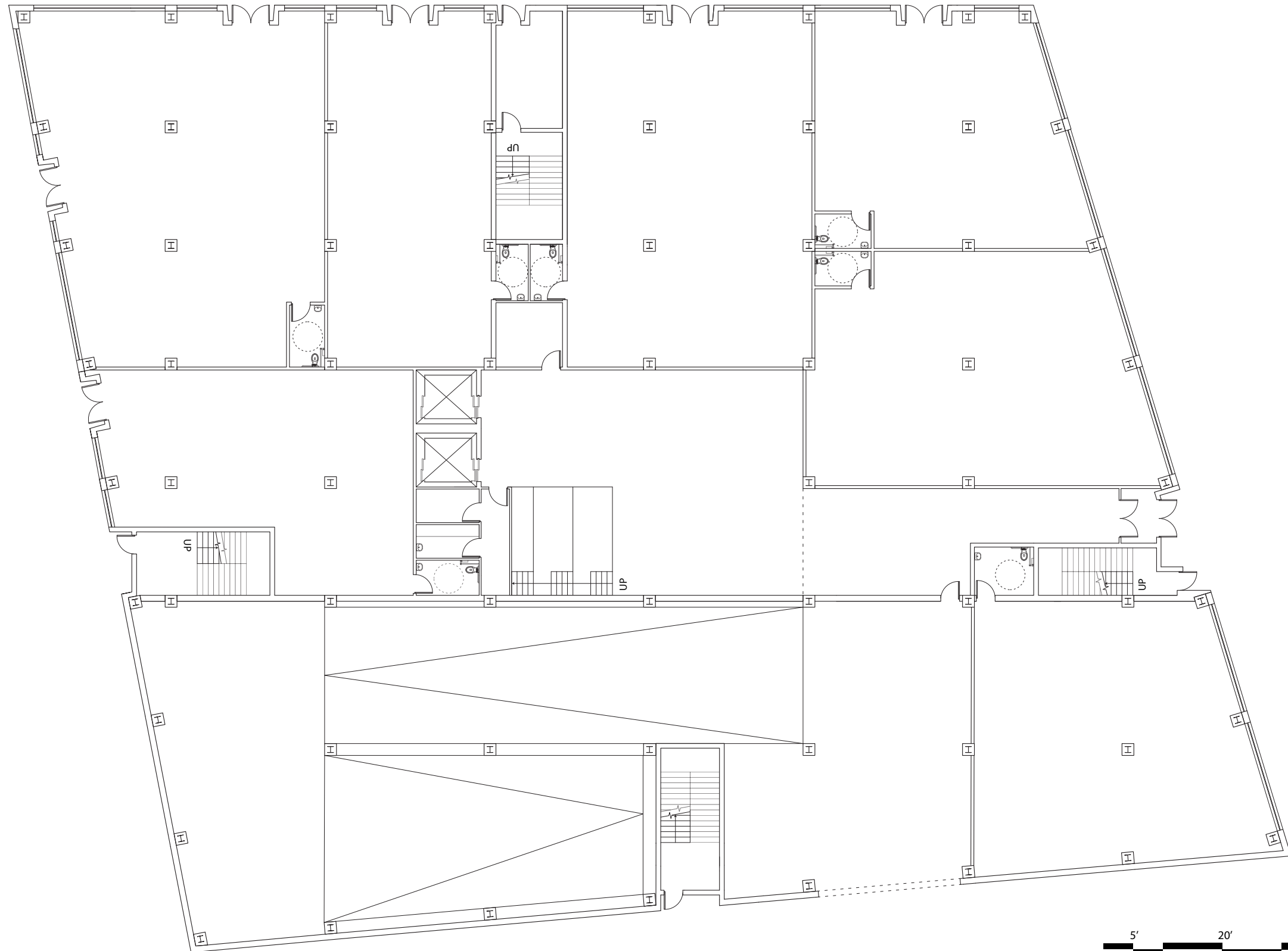

**2016 INTEGRATED BUILDING SYSTEMS**  
**ARCH 2178**  
 Hyunbae Chang | Marco Didonet |  
 Iris Kim | Jiseon Park | Natasha Ruiz

**FilterScape**  
**Commercial Building**  
 117 Wickenden Street, Providence RI 02903

**ARCHITECTURAL**  
 Building Plans | Ground Floor



**A100**

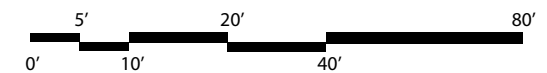
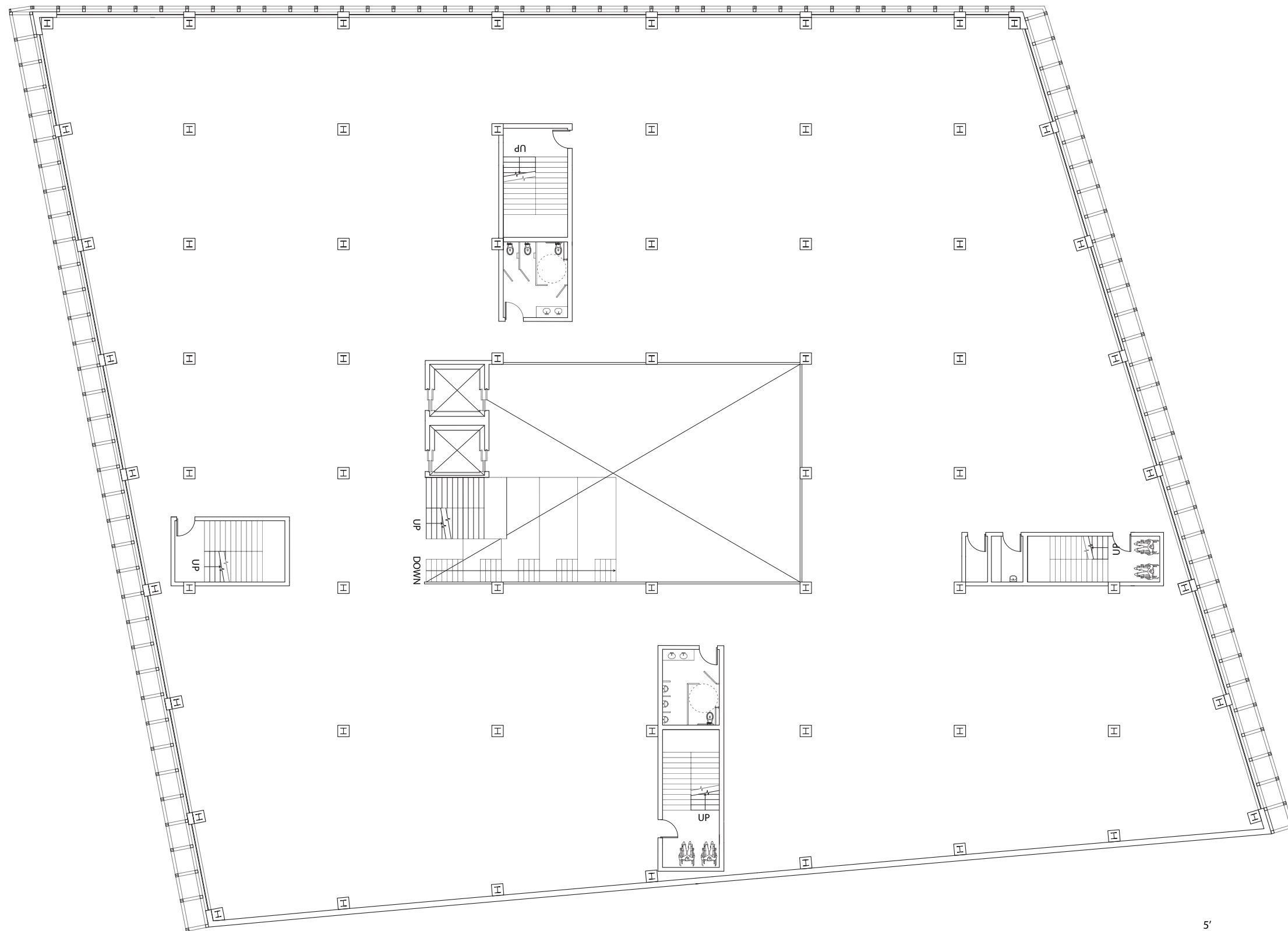

**2016 INTEGRATED BUILDING SYSTEMS**  
**ARCH 2178**  
 Hyunbae Chang | Marco Didonet |  
 Iris Kim | Jiseon Park | Natasha Ruiz

**FilterScape**  
**Commercial Building**  
 117 Wickenden Street, Providence RI 02903



**ARCHITECTURAL**  
 Building Plans | Upper Floors

**A101**

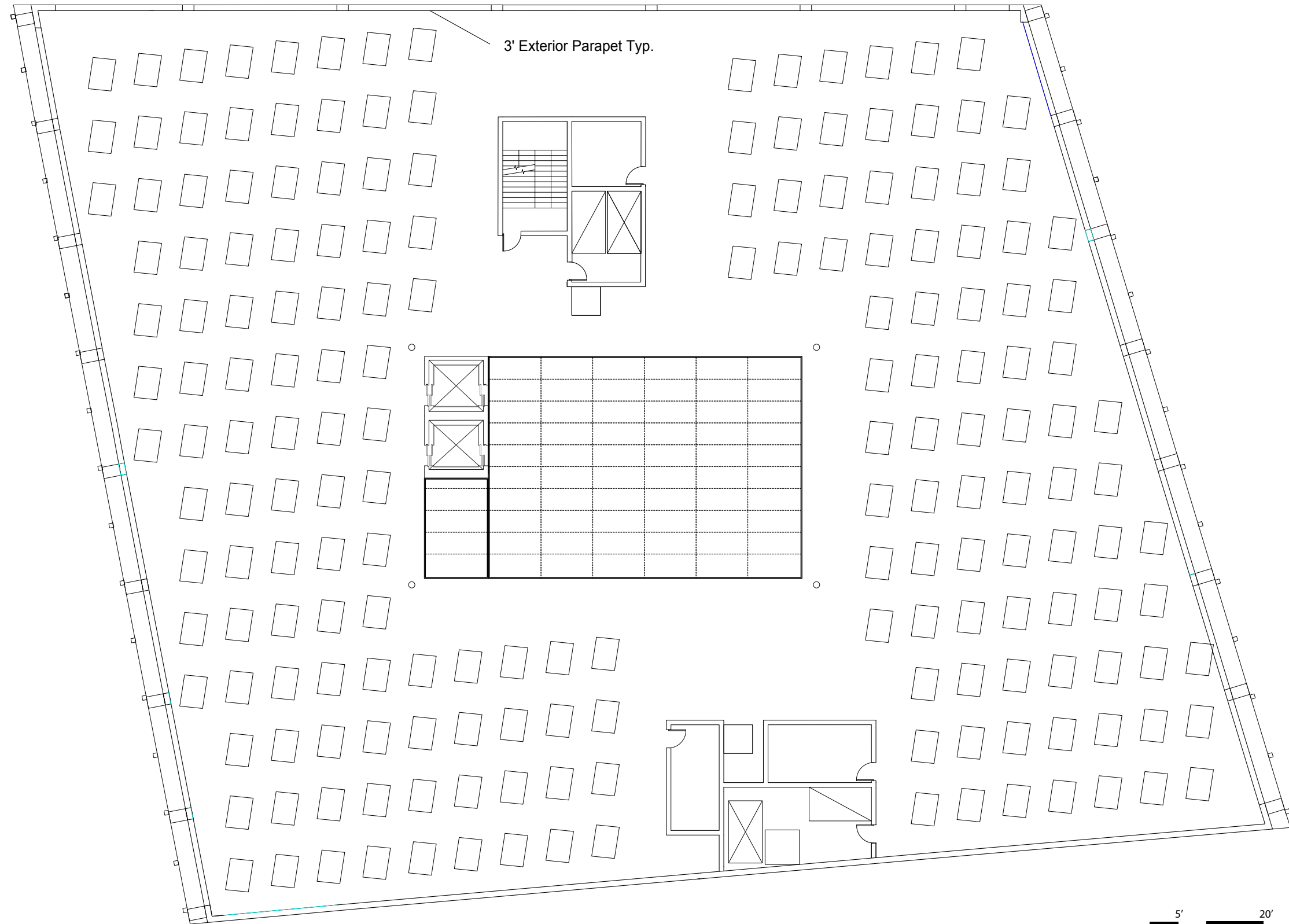

**2016 INTEGRATED BUILDING SYSTEMS  
ARCH 2178**

Hyunbae Chang | Marco Didonet |  
Iris Kim | Jiseon Park | Natasha Ruiz

# FilterScape

Commercial Building

117 Wickenden Street, Providence RI 02903

**ARCHITECTURAL**  
Building Plans | Roof Plan



**A102**

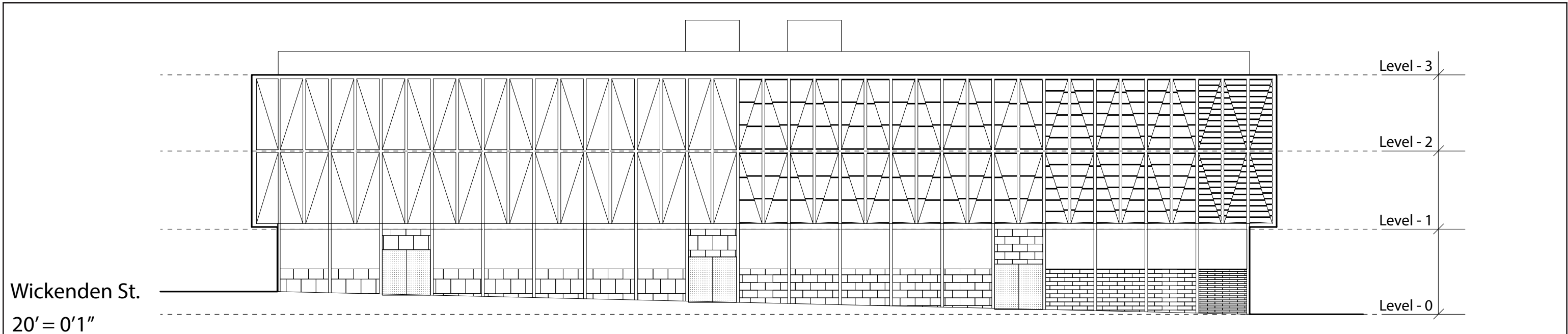

Wickenden St.  
20' = 0'1"

Level - 3  
Level - 2  
Level - 1  
Level - 0

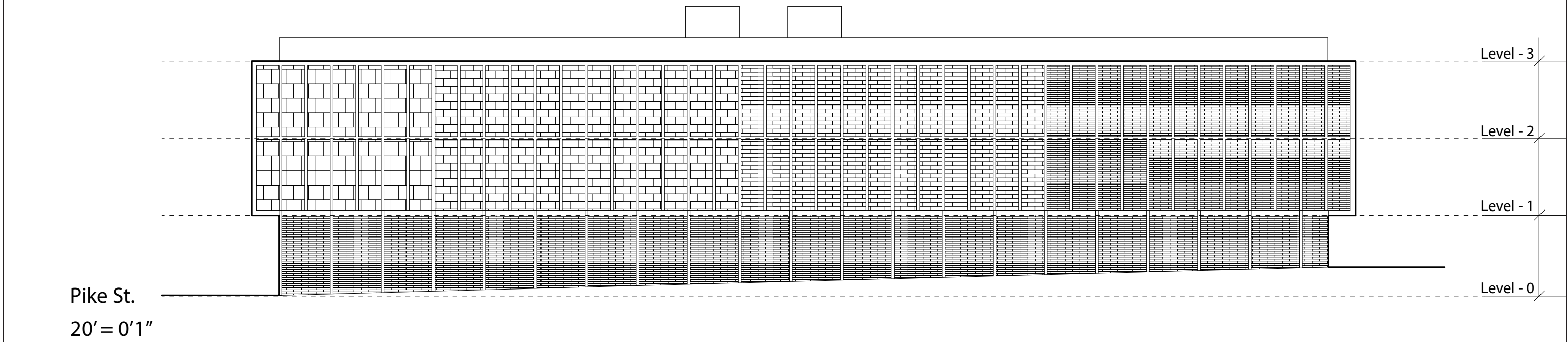

Pike St.  
20' = 0'1"

Level - 3  
Level - 2  
Level - 1  
Level - 0

2016 INTEGRATED BUILDING SYSTEMS  
ARCH 2178  
Hyunbae Chang | Marco Didonet |  
Iris Kim | Jiseon Park | Natasha Ruiz

**FilterScape**  
Commercial Building  
117 Wickenden Street, Providence RI 02903

ARCHITECTURAL  
Building Elevations

A200

Southwater St.  
20' = 0'1"

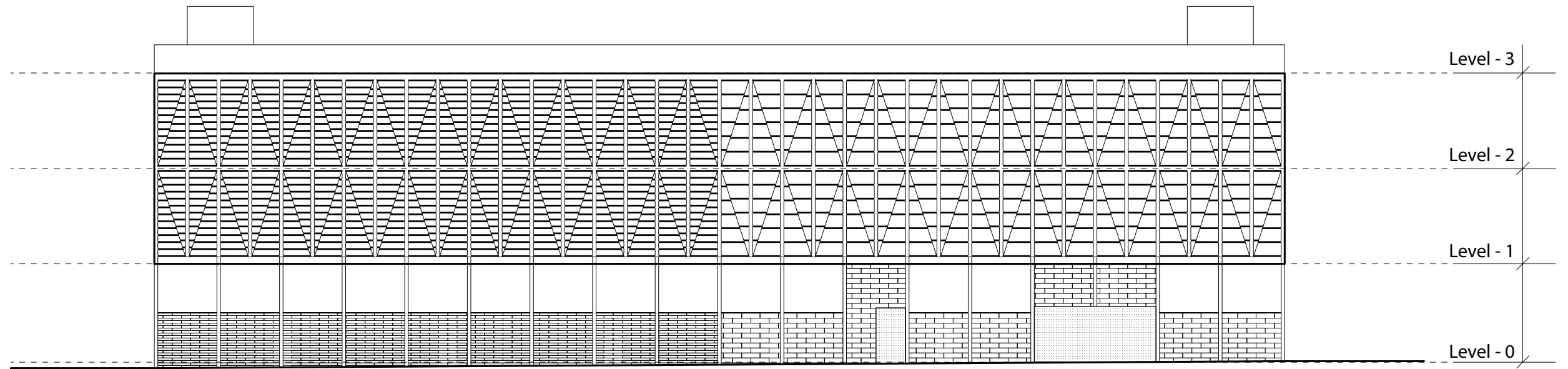

Southmain St.  
20' = 0'1"

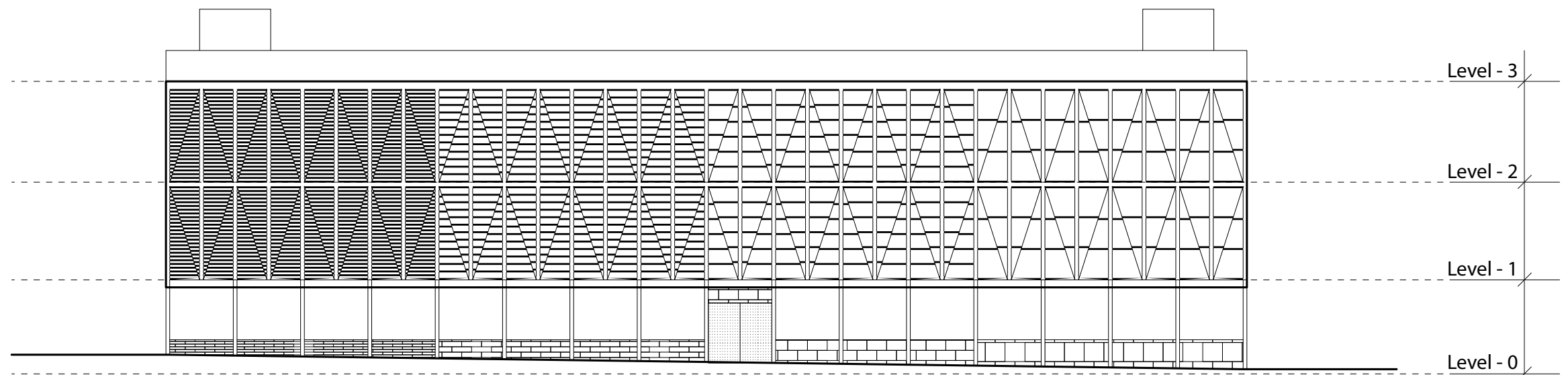

2016 INTEGRATED BUILDING SYSTEMS  
ARCH 2178  
Hyunbae Chang | Marco Didonet |  
Iris Kim | Jiseon Park | Natasha Ruiz

**FilterScape**  
Commercial Building  
117 Wickenden Street, Providence RI 02903

ARCHITECTURAL  
Building Elevations

A201



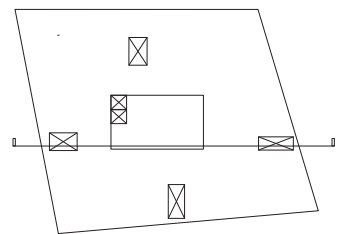
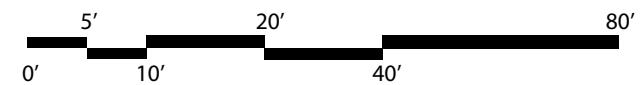
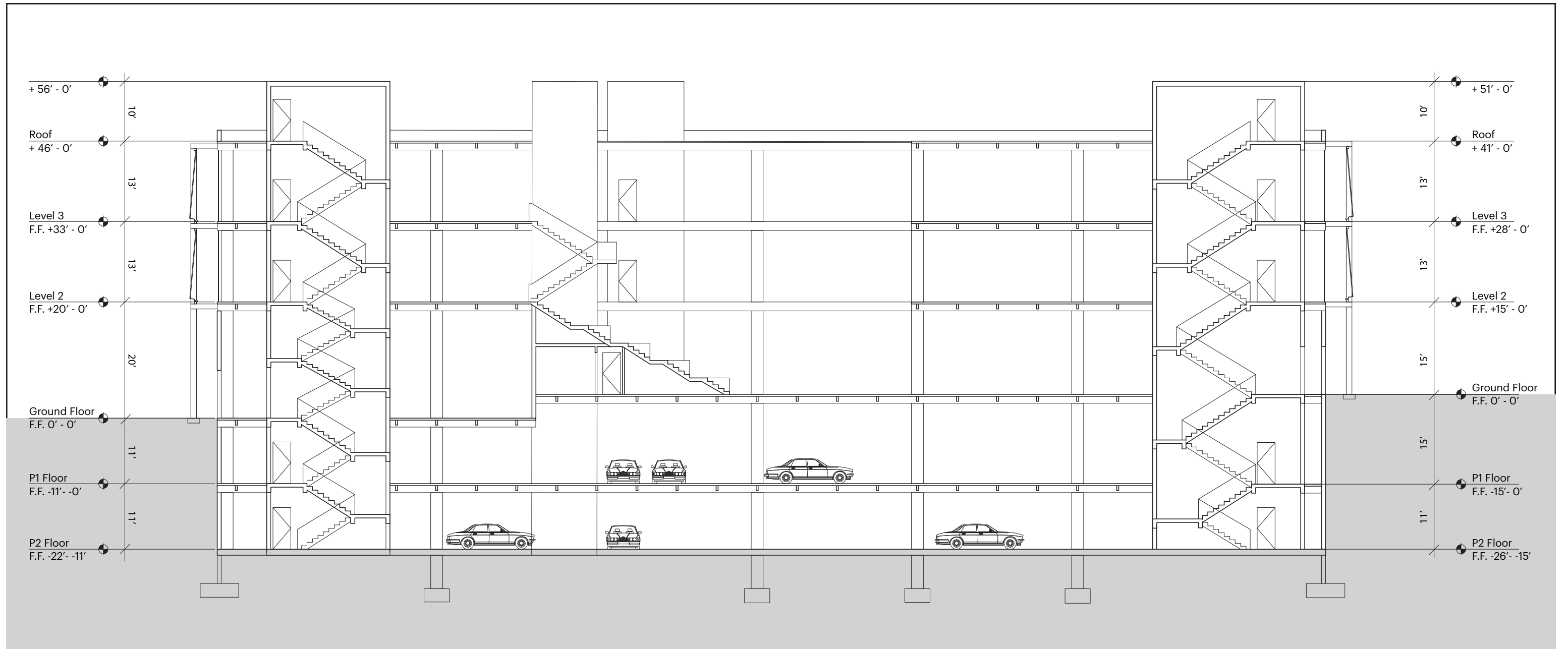

2016 INTEGRATED BUILDING SYSTEMS  
 ARCH 2178  
 Hyunbae Chang | Marco Didonet |  
 Iris Kim | Jiseon Park | Natasha Ruiz

**FilterScape**  
 Commercial Building  
 117 Wickenden Street, Providence RI 02903

ARCHITECTURAL  
 Building Sections | Section A

A300

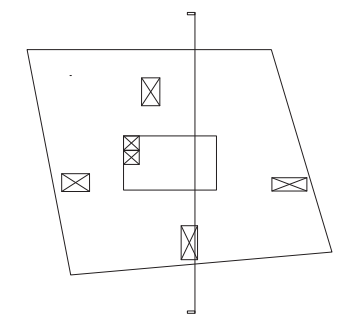
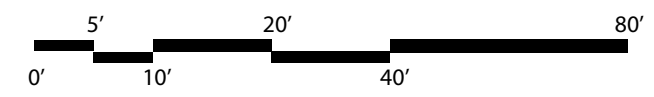
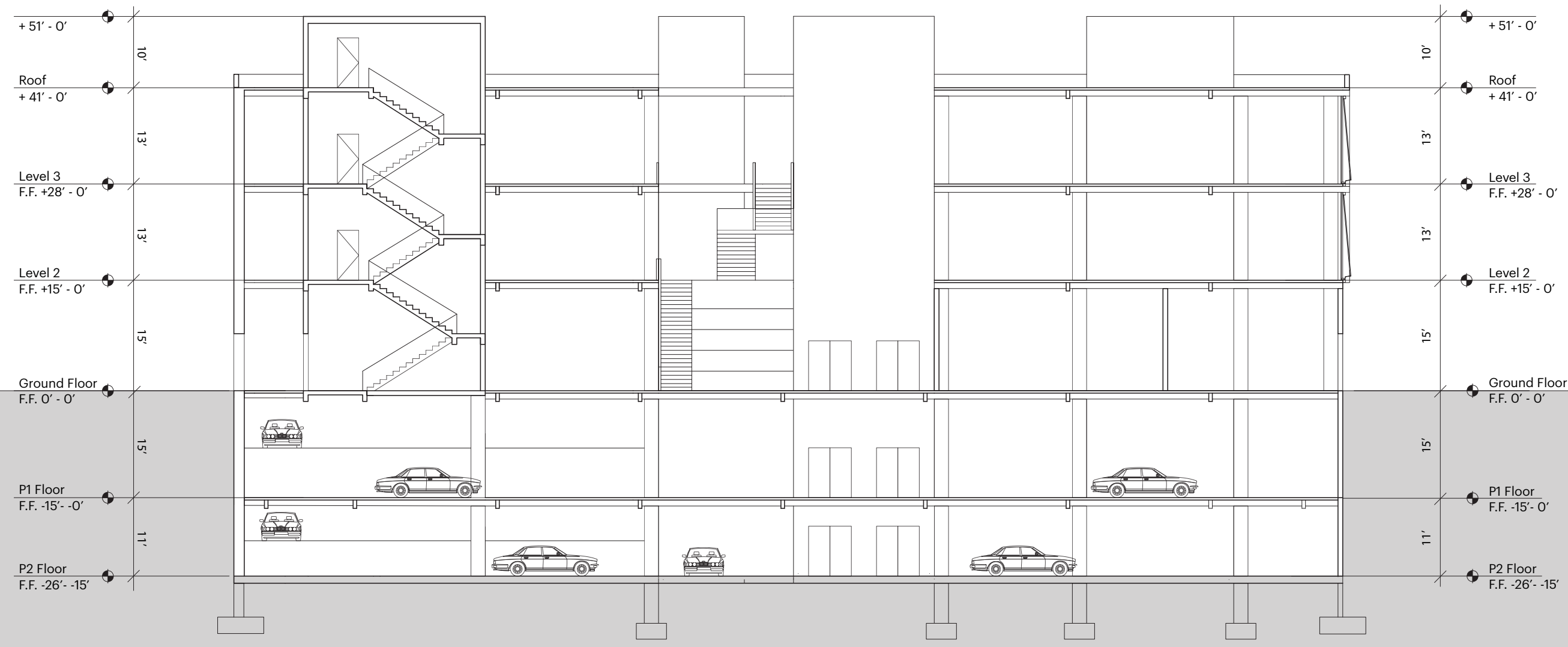

**2016 INTEGRATED BUILDING SYSTEMS  
ARCH 2178**  
Hyunbae Chang | Marco Didonet |  
Iris Kim | Jiseon Park | Natasha Ruiz

**FilterScape**  
Commercial Building  
117 Wickenden Street, Providence RI 02903

**ARCHITECTURAL**  
Building Sections | Section B  
**A301**

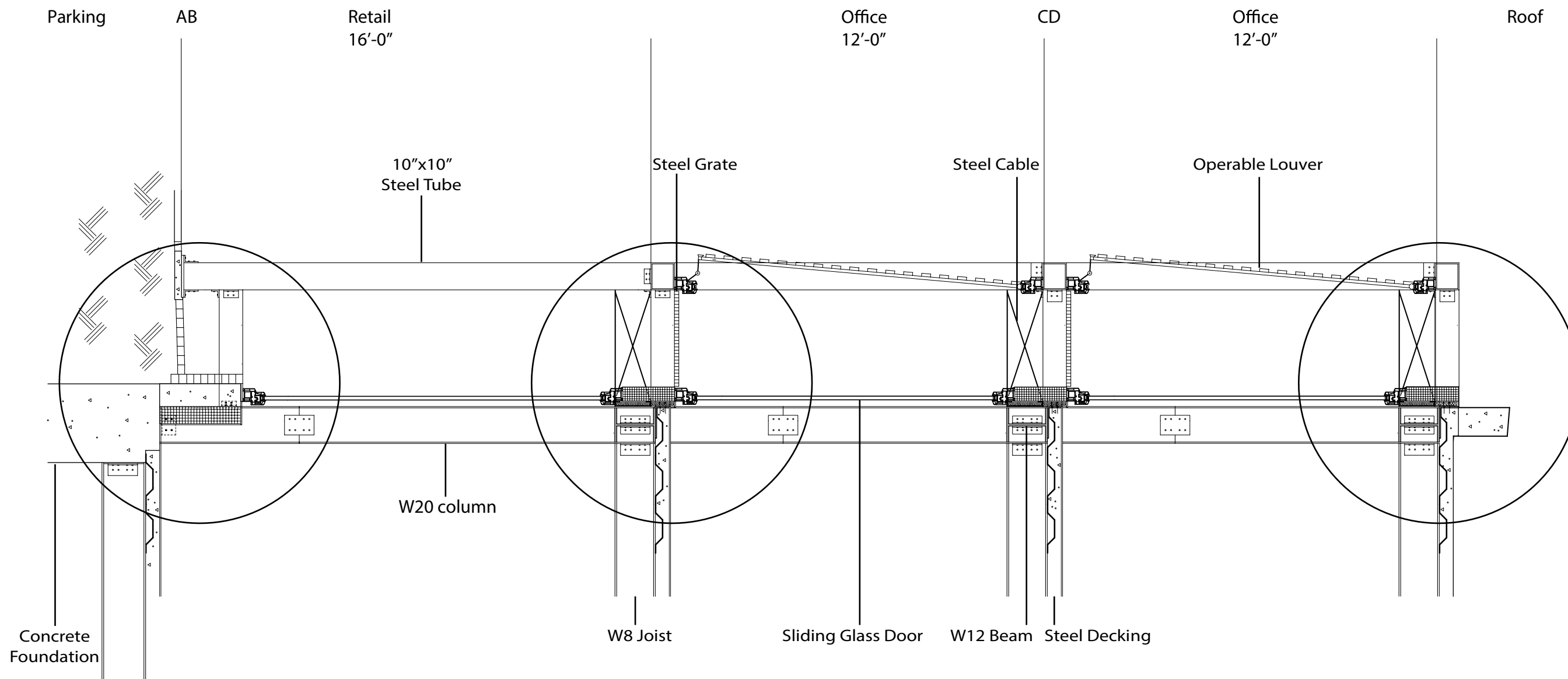

2016 INTEGRATED BUILDING SYSTEMS  
 ARCH 2178  
 Hyunbae Chang | Marco Didonet |  
 Iris Kim | Jiseon Park | Natasha Ruiz

**FilterScape**  
 Commercial Building  
 117 Wickenden Street, Providence RI 02903

ARCHITECTURAL  
 Principle Wall Sections | Double Skin

A400

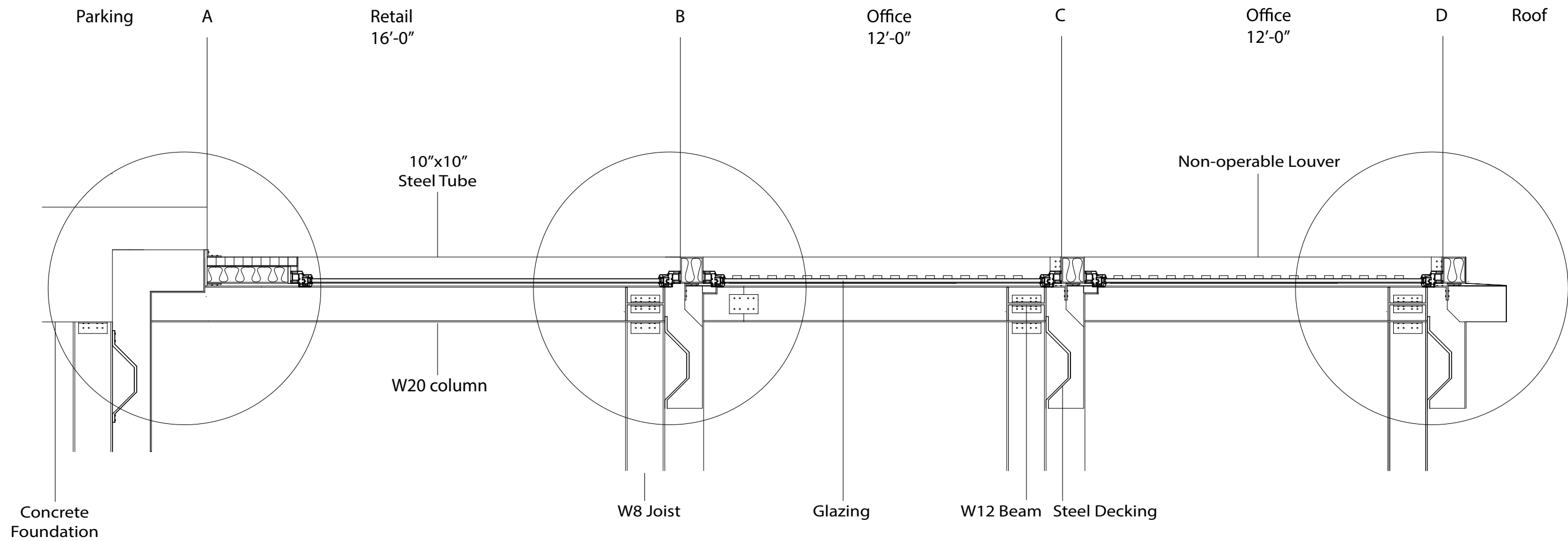

**2016 INTEGRATED BUILDING SYSTEMS**  
**ARCH 2178**  
 Hyunbae Chang | Marco Didonet |  
 Iris Kim | Jiseon Park | Natasha Ruiz

**FilterScape**  
**Commercial Building**  
 117 Wickenden Street, Providence RI 02903

**ARCHITECTURAL**  
 Principle Wall Sections | Glass  
 Curtain Wall

**A401**

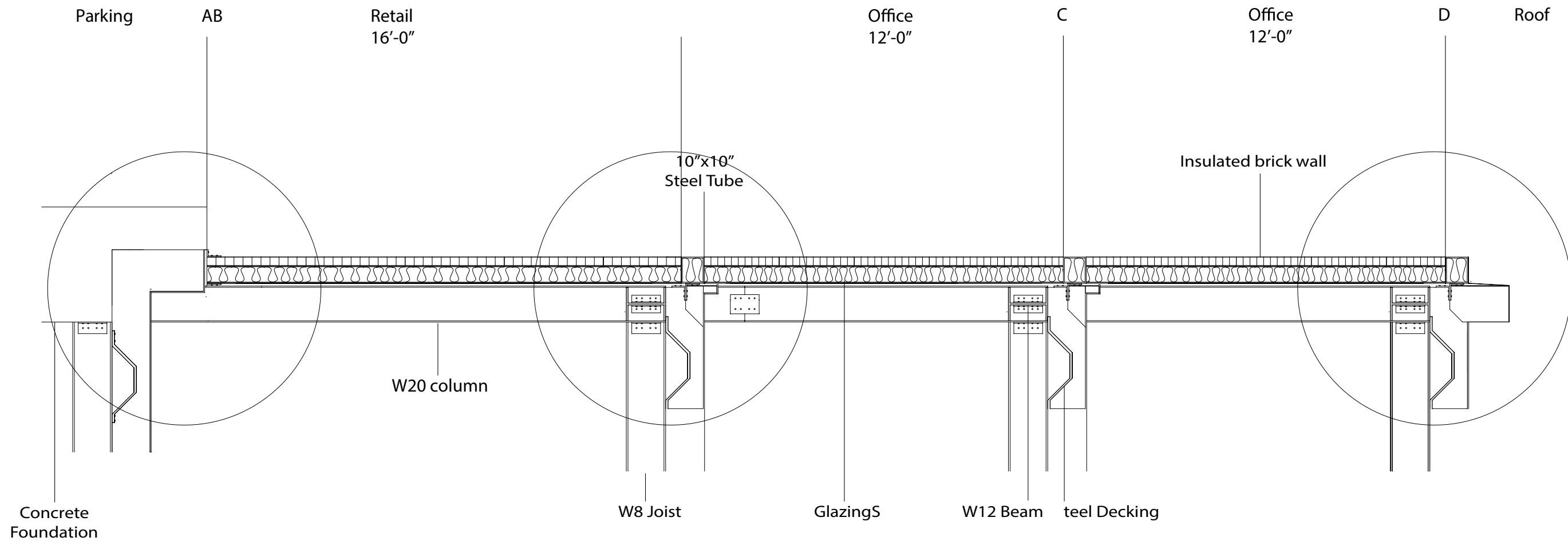

2016 INTEGRATED BUILDING SYSTEMS  
 ARCH 2178  
 Hyunbae Chang | Marco Didonet |  
 Iris Kim | Jiseon Park | Natasha Ruiz

**FilterScape**  
 Commercial Building  
 117 Wickenden Street, Providence RI 02903

ARCHITECTURAL  
 Principle Wall Sections | Brick Wall

A402

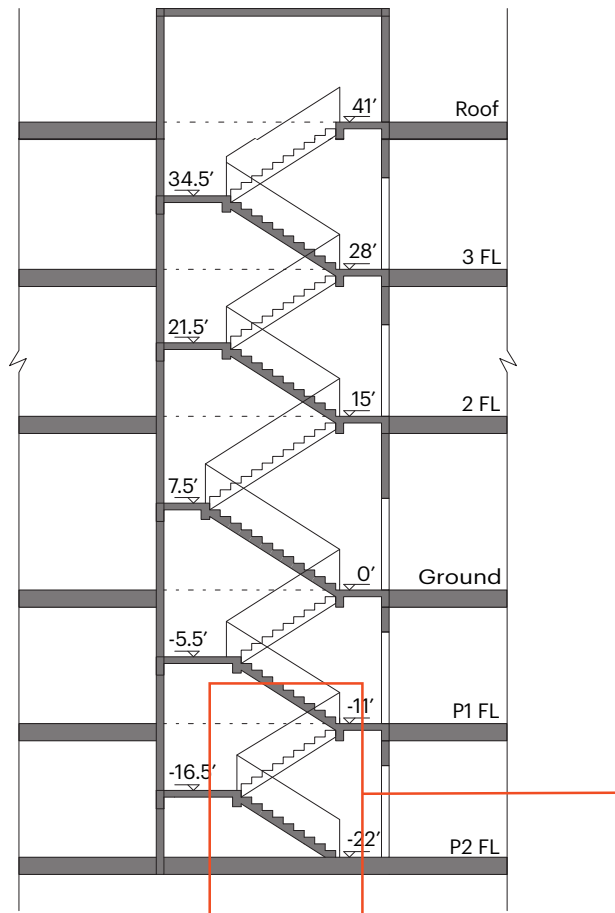

1/16" = 1'-0"

### Stair Rail Construction

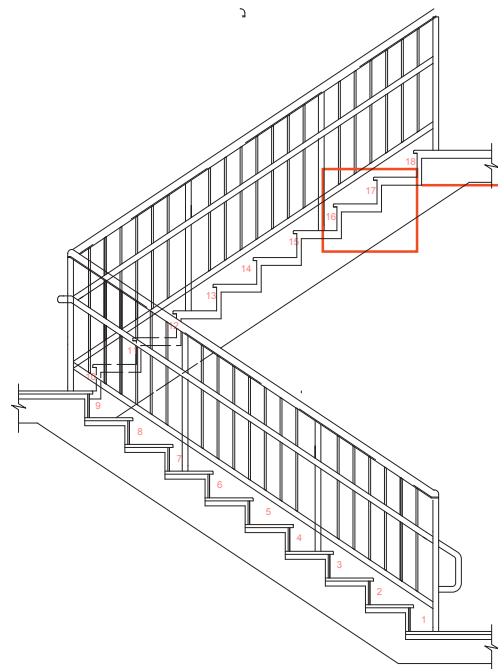

Elevation 1/4" = 1'-0"

### Tread/Riser Construction

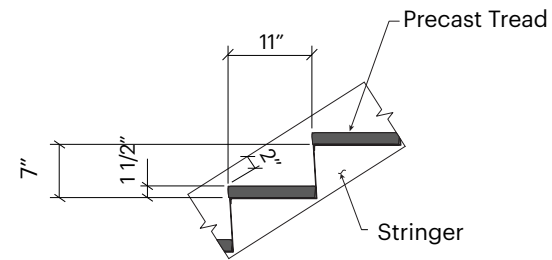

### Smooth Plate Landing

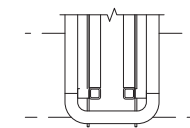
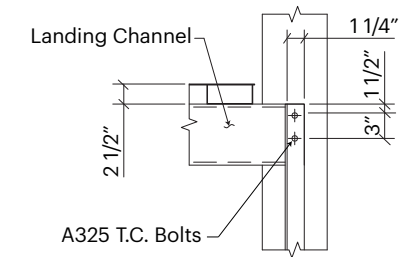

Top View

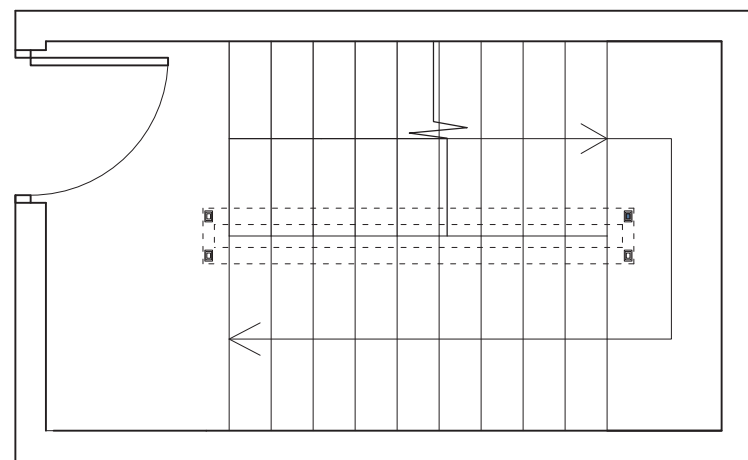

Plan View 1/4" = 1'-0"

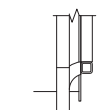

Top View

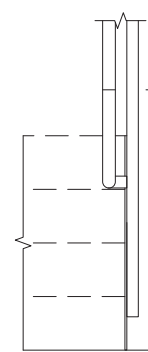

End View

Starter Rail without level off hand rail

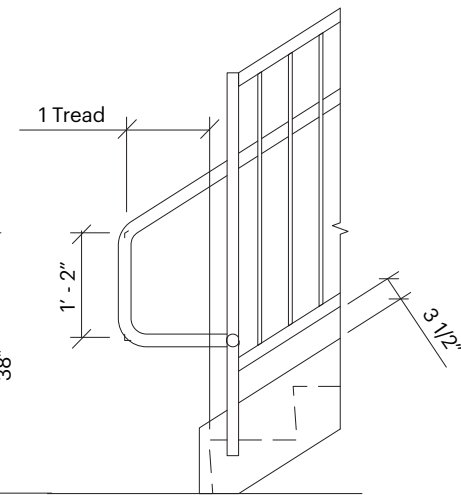

Elevation

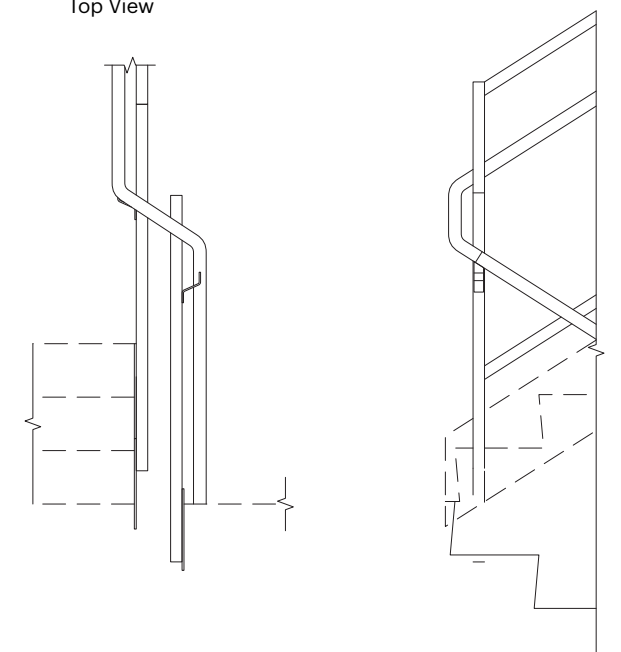

End View

Rail with standard top - standard bottom

2016 INTEGRATED BUILDING SYSTEMS  
ARCH 2178  
Hyunbae Chang | Marco Didonet |  
Iris Kim | Jiseon Park | Natasha Ruiz

**FilterScape**  
Commercial Building  
117 Wickenden Street, Providence RI 02903

ARCHITECTURAL  
Vertical Circulation

A500

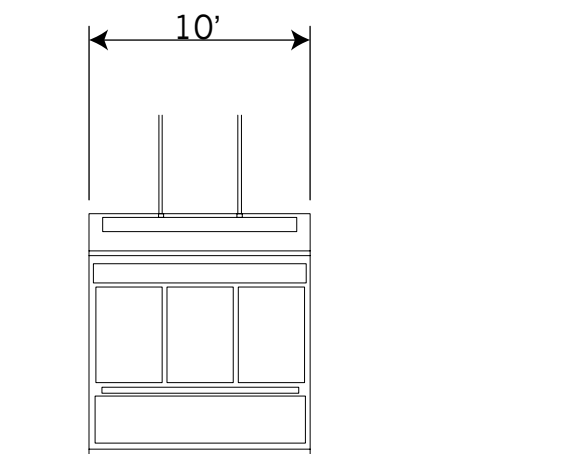
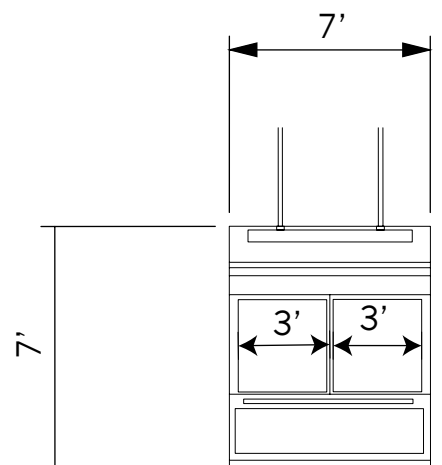
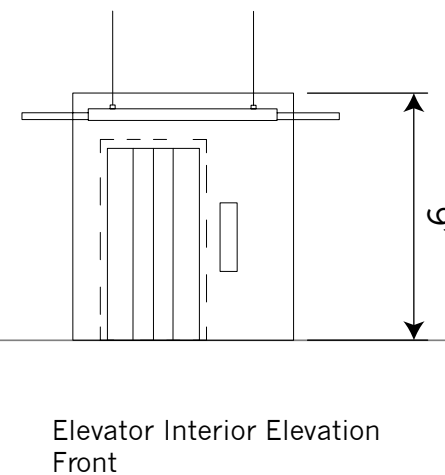
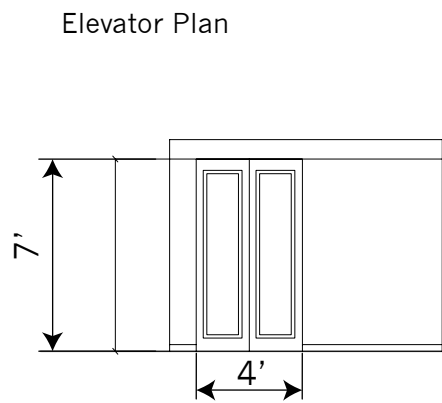
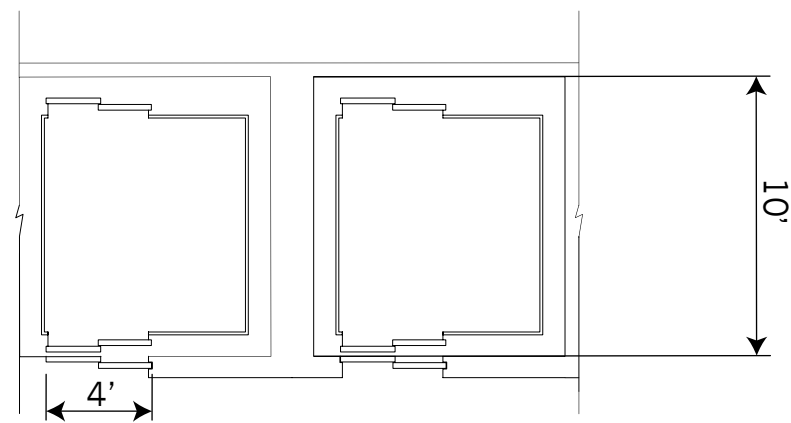
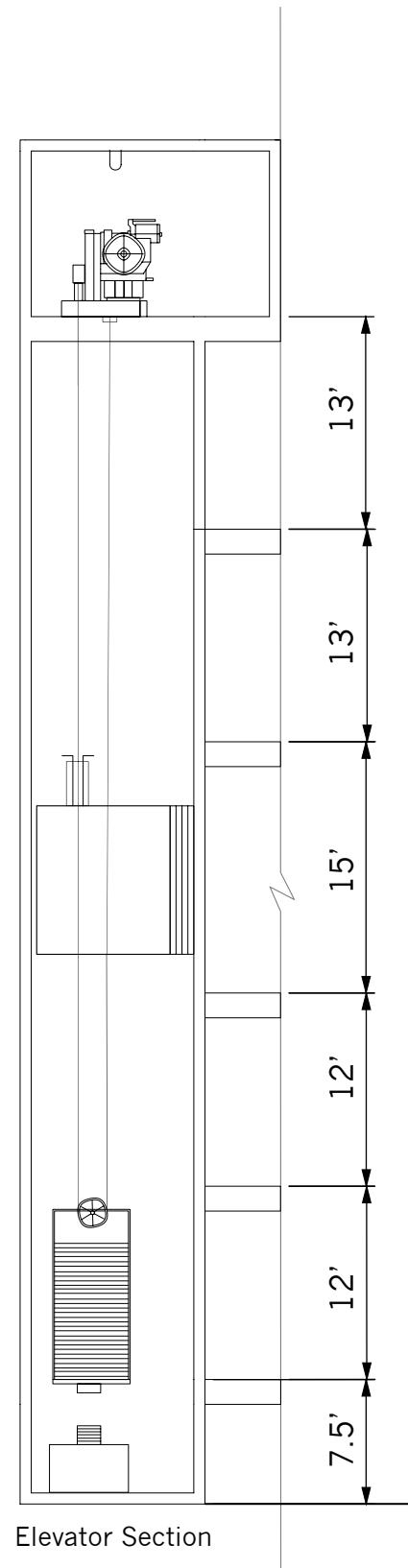

2016 INTEGRATED BUILDING SYSTEMS  
 ARCH 2178  
 Hyunbae Chang | Marco Didonet |  
 Iris Kim | Jiseon Park | Natasha Ruiz

**FilterScape**  
 Commercial Building  
 117 Wickenden Street, Providence RI 02903

ARCHITECTURAL  
 Vertical Circulation  
 Elevator Detail

A501

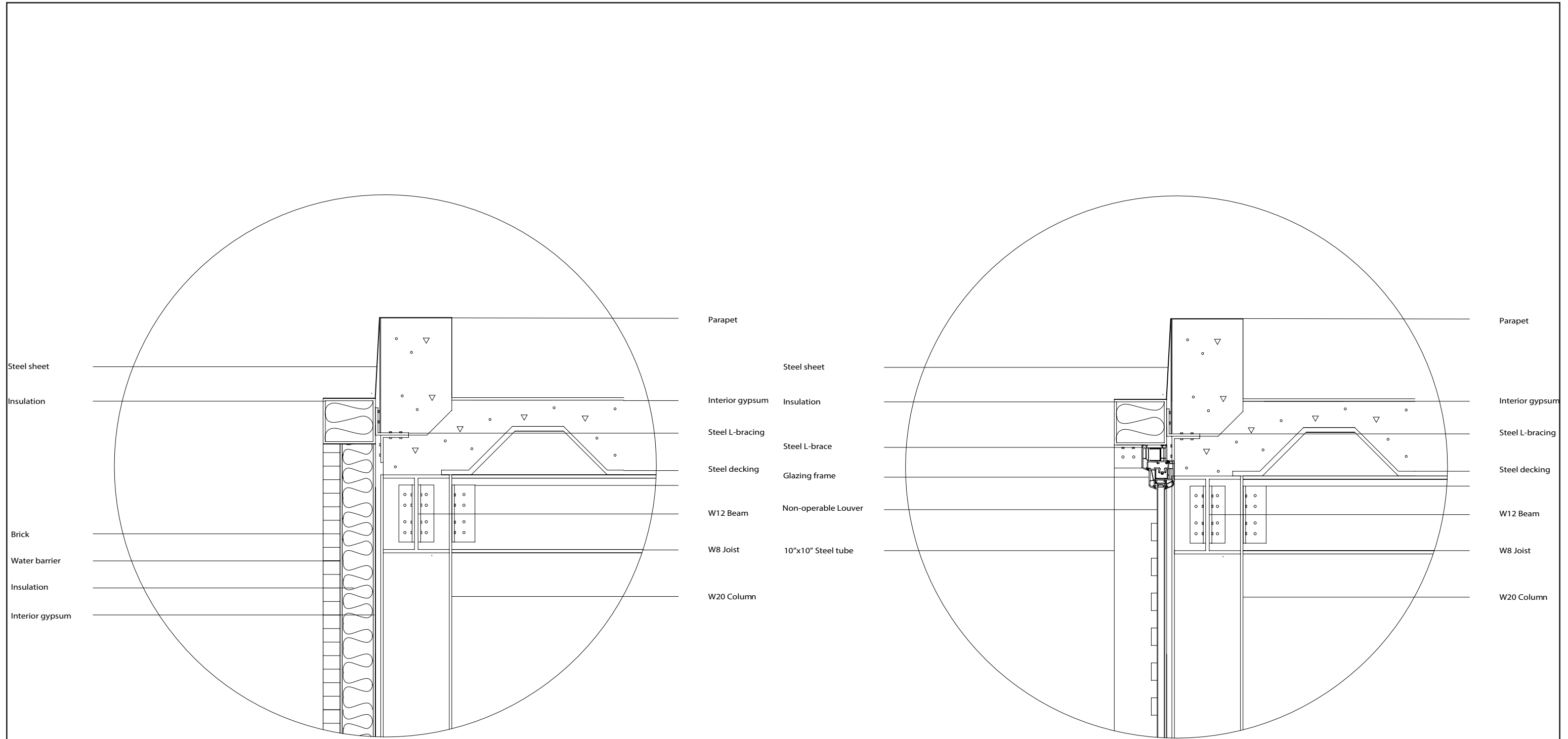

2016 INTEGRATED BUILDING SYSTEMS  
 ARCH 2178  
 Hyunbae Chang | Marco Didonet |  
 Iris Kim | Jiseon Park | Natasha Ruiz

**FilterScape**  
 Commercial Building  
 117 Wickenden Street, Providence RI 02903

ARCHITECTURAL  
 Roof Details

A700



at atrium  
1/A701

Glazing  
Glazing frame  
Water barrier  
  
Water barrier  
Brick cladding  
  
Steel L-brace  
Concrete foundation

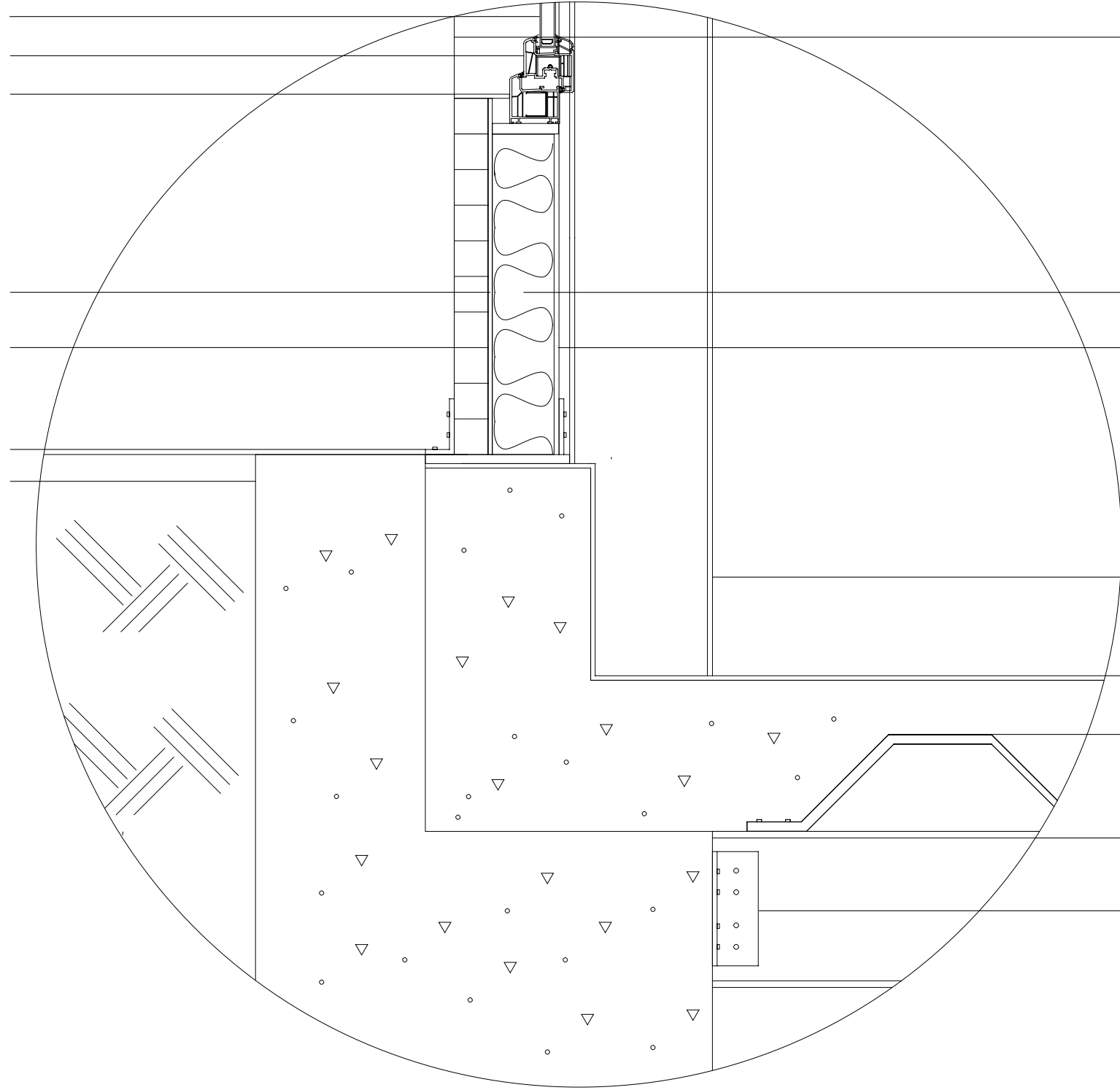

10"x10" Steel tube  
  
Insulation  
Interior gypsum  
  
W20 Column  
  
Interior gypsum  
Steel decking  
W8 Joist  
Steel L-bracing

**2016 INTEGRATED BUILDING SYSTEMS**  
**ARCH 2178**  
Hyunbae Chang | Marco Didonet |  
Iris Kim | Jiseon Park | Natasha Ruiz

**FilterScape**  
**Commercial Building**  
117 Wickenden Street, Providence RI 02903

**ARCHITECTURAL**  
Interior Details

**A701**

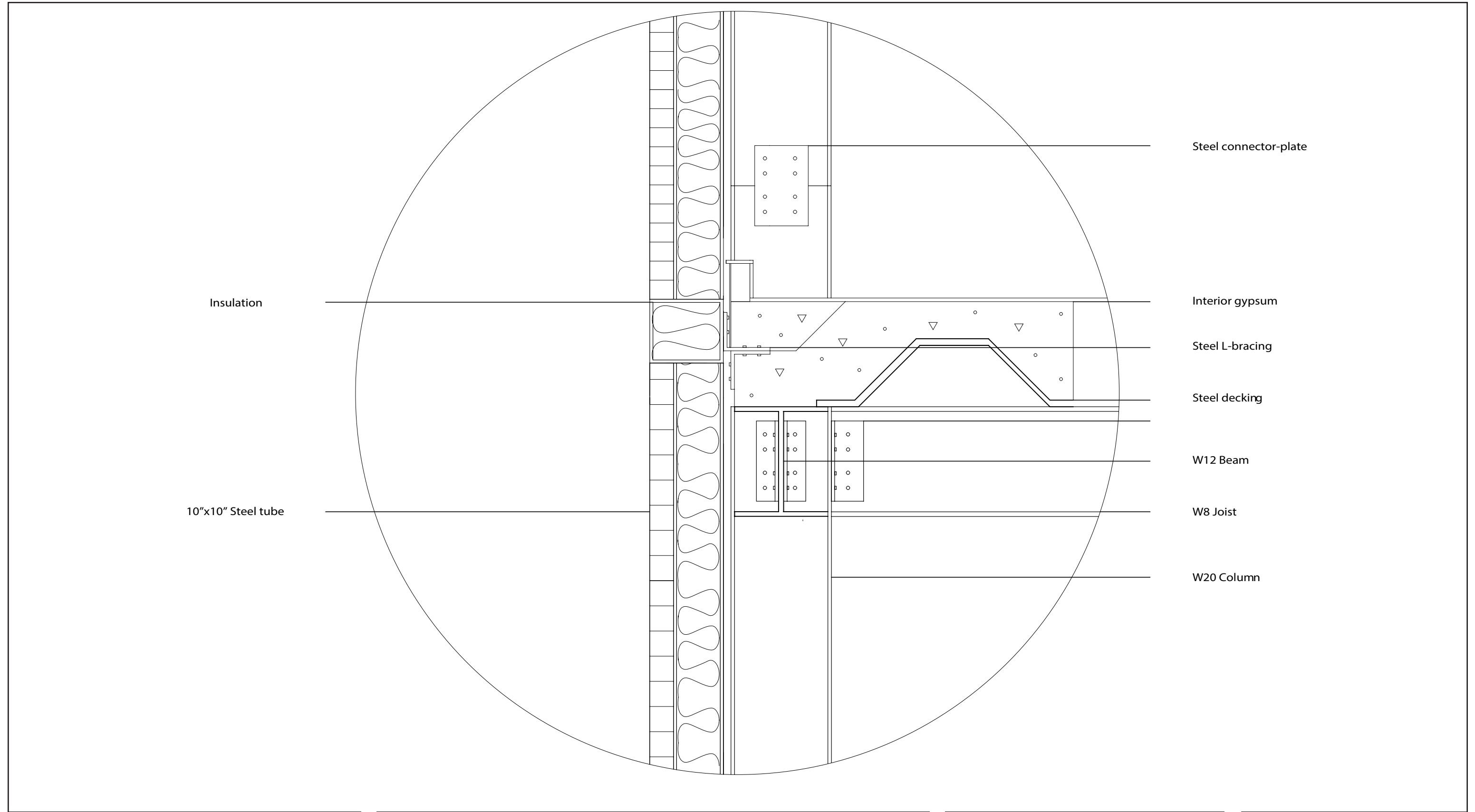

Insulation

10"x10" Steel tube

Steel connector-plate

Interior gypsum

Steel L-bracing

Steel decking

W12 Beam

W8 Joist

W20 Column

2016 INTEGRATED BUILDING SYSTEMS

ARCH 2178

Hyunbae Chang | Marco Didonet |  
Iris Kim | Jiseon Park | Natasha Ruiz

**FilterScape**

Commercial Building

117 Wickenden Street, Providence RI 02903

ARCHITECTURAL

Interior Details

A702

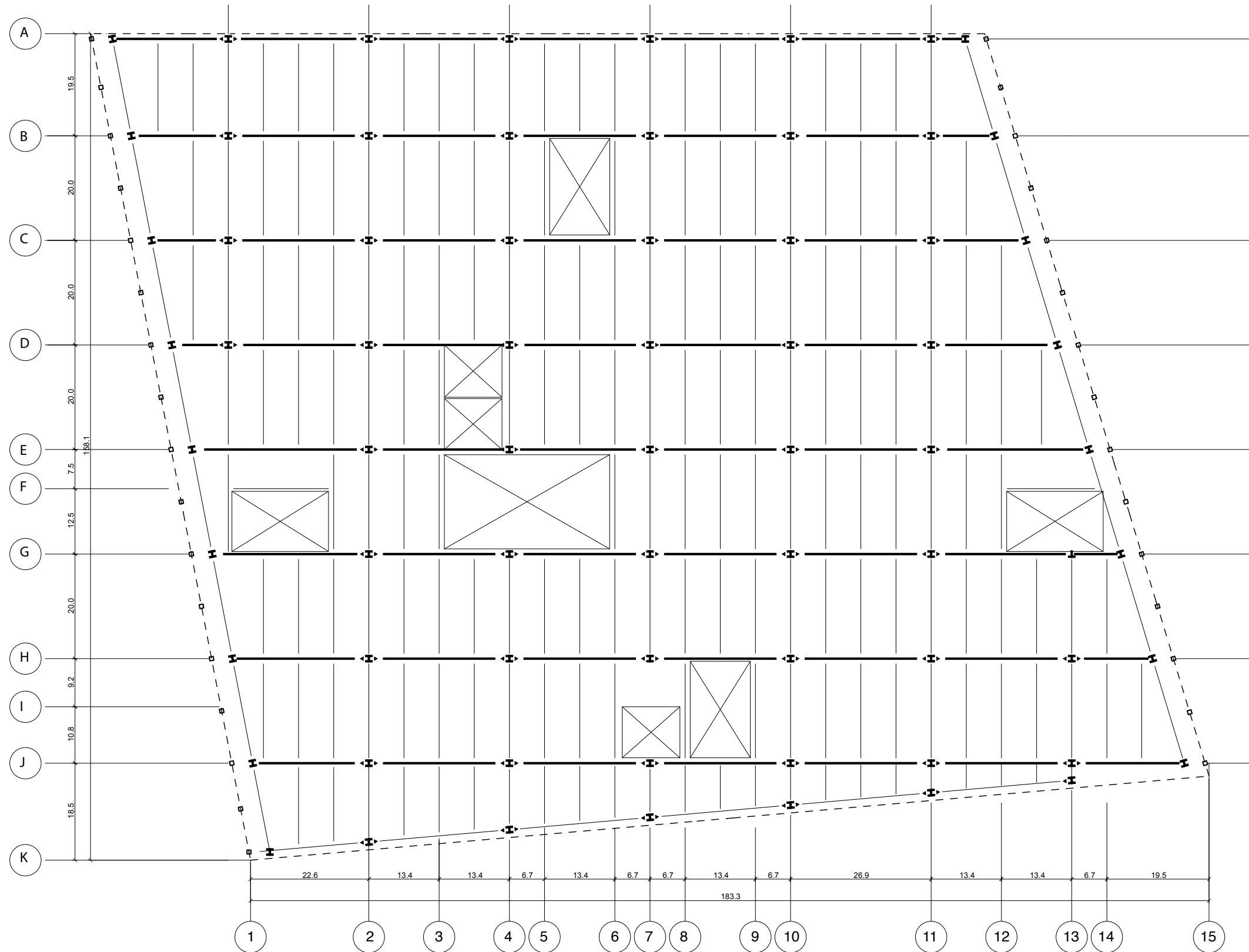

2016 INTEGRATED BUILDING SYSTEMS  
 ARCH 2178  
 Hyunbae Chang | Marco Didonet |  
 Iris Kim | Jiseon Park | Natasha Ruiz

**FilterScape**  
 Commercial Building  
 117 Wickenden Street, Providence RI 02903

**STRUCTURAL**  
 Framing Plan | Ground Floor



S100

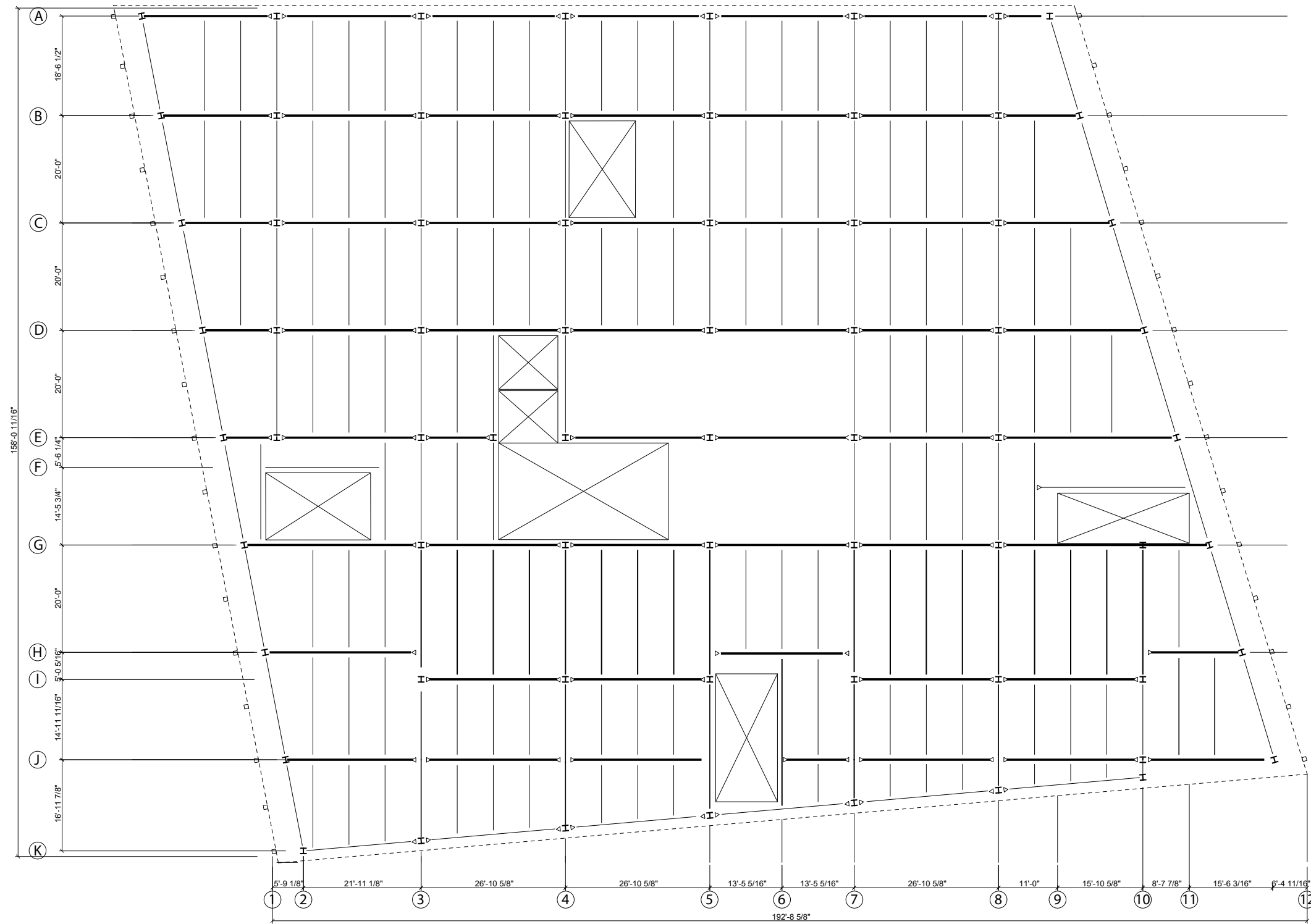

**2016 INTEGRATED BUILDING SYSTEMS**  
**ARCH 2178**  
 Hyunbae Chang | Marco Didonet |  
 Iris Kim | Jiseon Park | Natasha Ruiz

**FilterScape**  
**Commercial Building**  
 117 Wickenden Street, Providence RI 02903

**STRUCTURAL**  
 Framing Plan | Upper Floors



**S101**

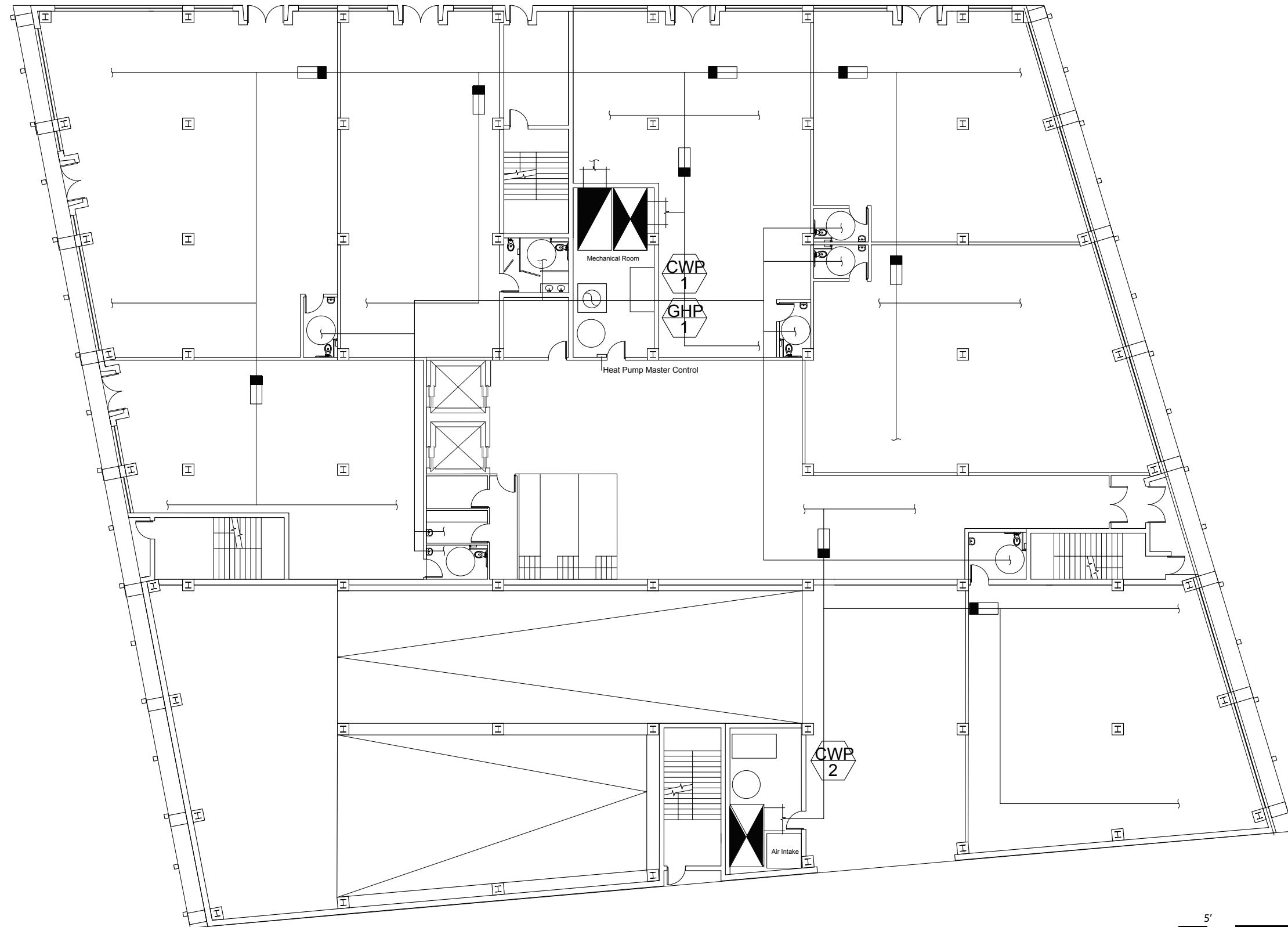

2016 INTEGRATED BUILDING SYSTEMS  
 ARCH 2178  
 Hyunbae Chang | Marco Didonet |  
 Iris Kim | Jiseon Park | Natasha Ruiz

**FilterScape**  
 Commercial Building  
 117 Wickenden Street, Providence RI 02903



**MECHANICAL**  
 Mechanical Ground

**M101.1**

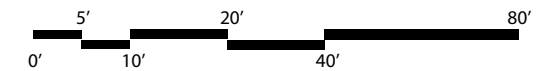
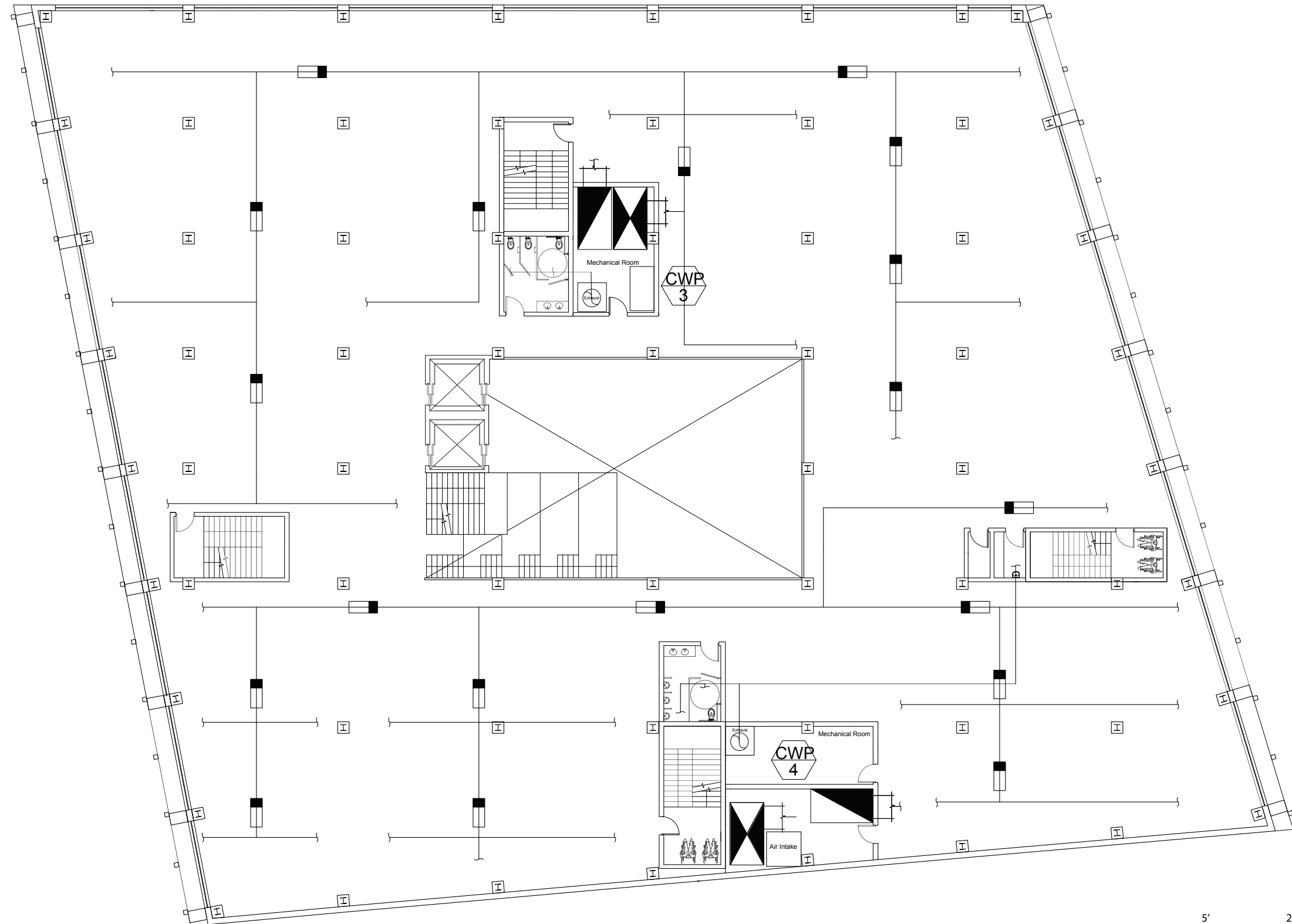

**2016 INTEGRATED BUILDING SYSTEMS**  
**ARCH 2178**  
 Hyunbae Chang | Marco Didonet |  
 Iris Kim | Jiseon Park | Natasha Ruiz

**FilterScape**  
**Commercial Building**  
 117 Wickenden Street, Providence RI 02903



**MECHANICAL**  
 Mechanical Upper Plan

**M101.2**

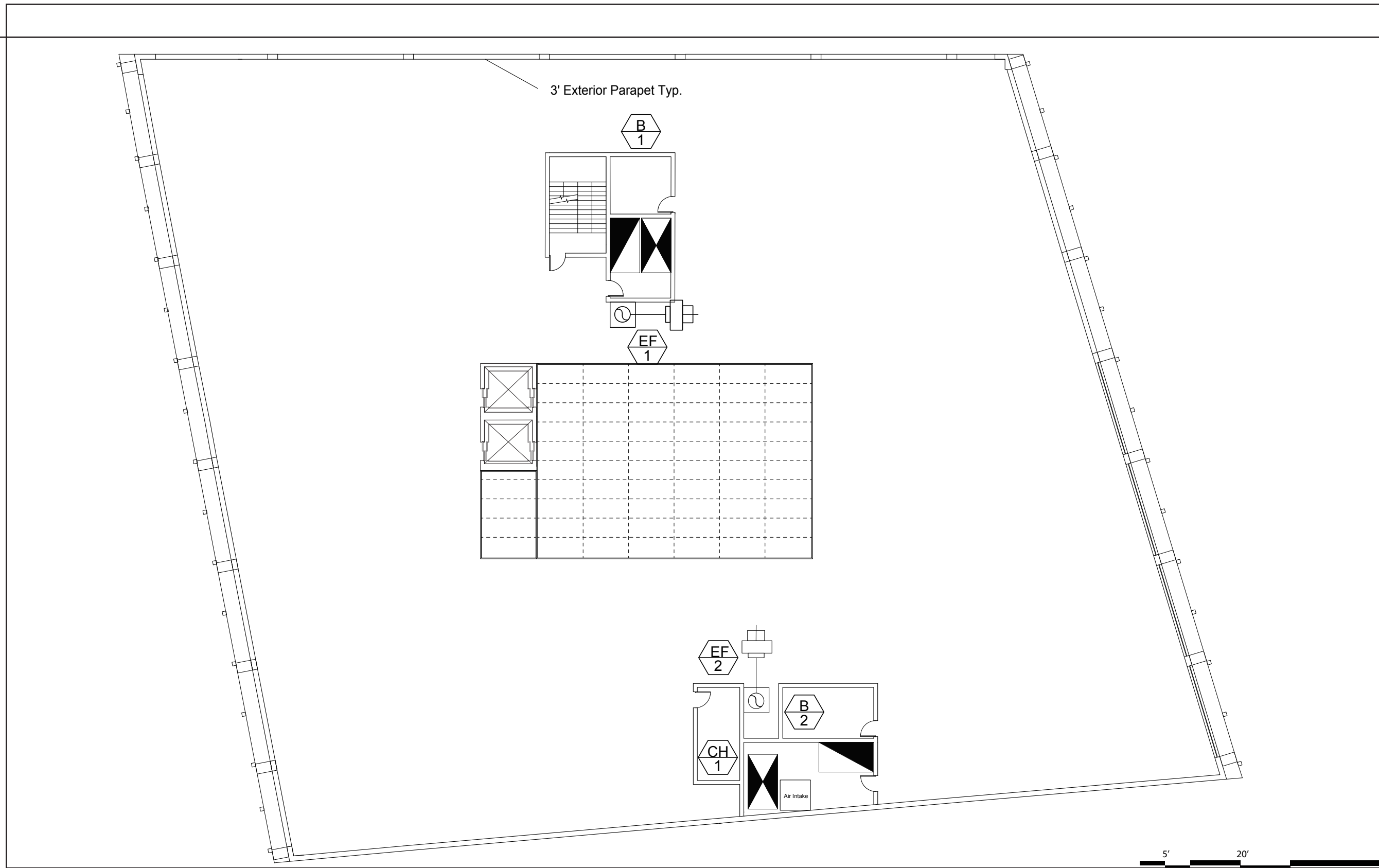

2016 INTEGRATED BUILDING SYSTEMS  
 ARCH 2178  
 Hyunbae Chang | Marco Didonet |  
 Iris Kim | Jiseon Park | Natasha Ruiz

**FilterScape**  
 Commercial Building  
 117 Wickenden Street, Providence RI 02903



**MECHANICAL**  
 Mechanical Roof Plan

M101.3

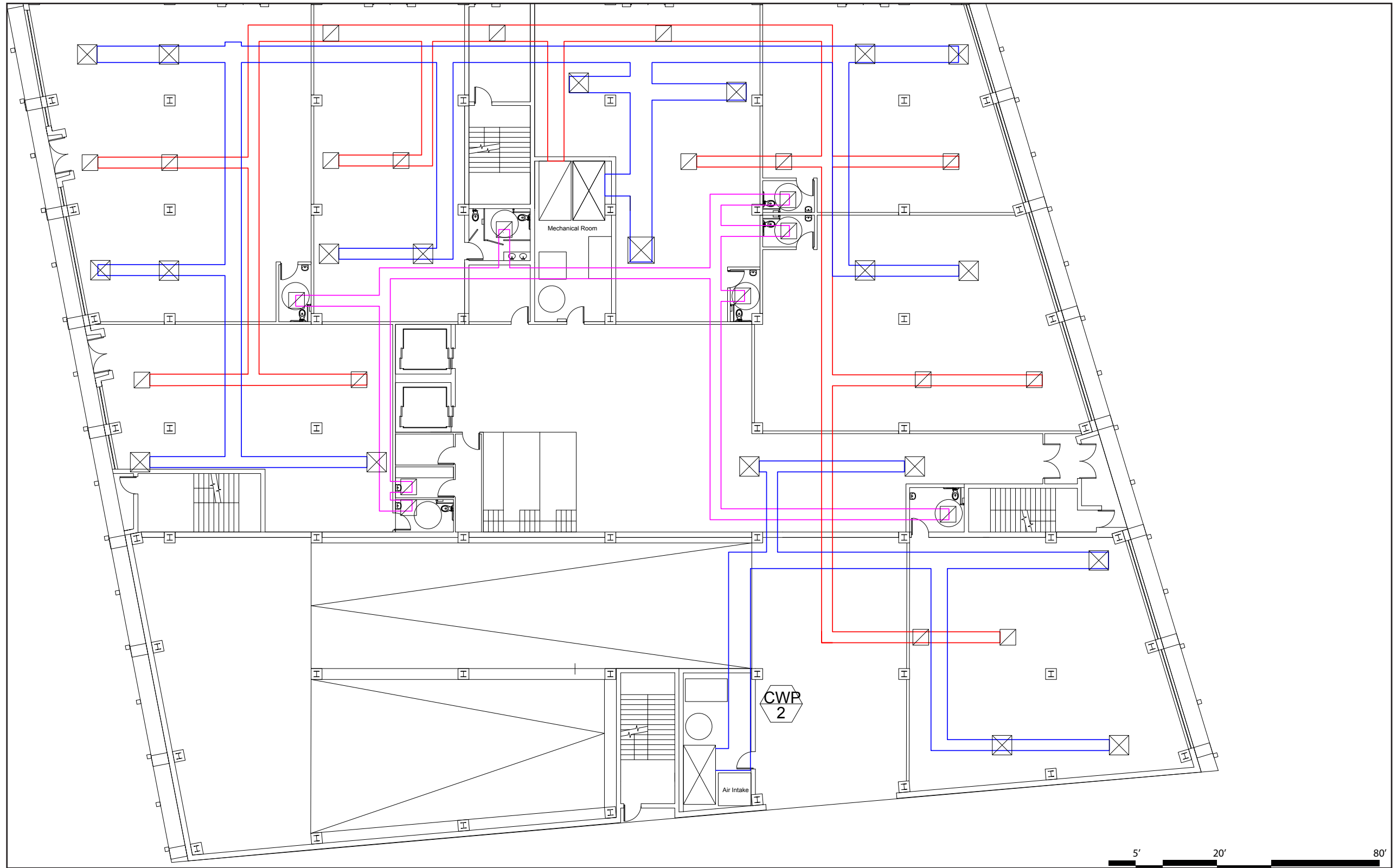

**2016 INTEGRATED BUILDING SYSTEMS**  
**ARCH 2178**  
 Hyunbae Chang | Marco Didonet |  
 Iris Kim | Jiseon Park | Natasha Ruiz

**FilterScape**  
**Commercial Building**  
 117 Wickenden Street, Providence RI 02903



**MECHANICAL**  
 HVAC Drawings | Ground Floor

**M102**



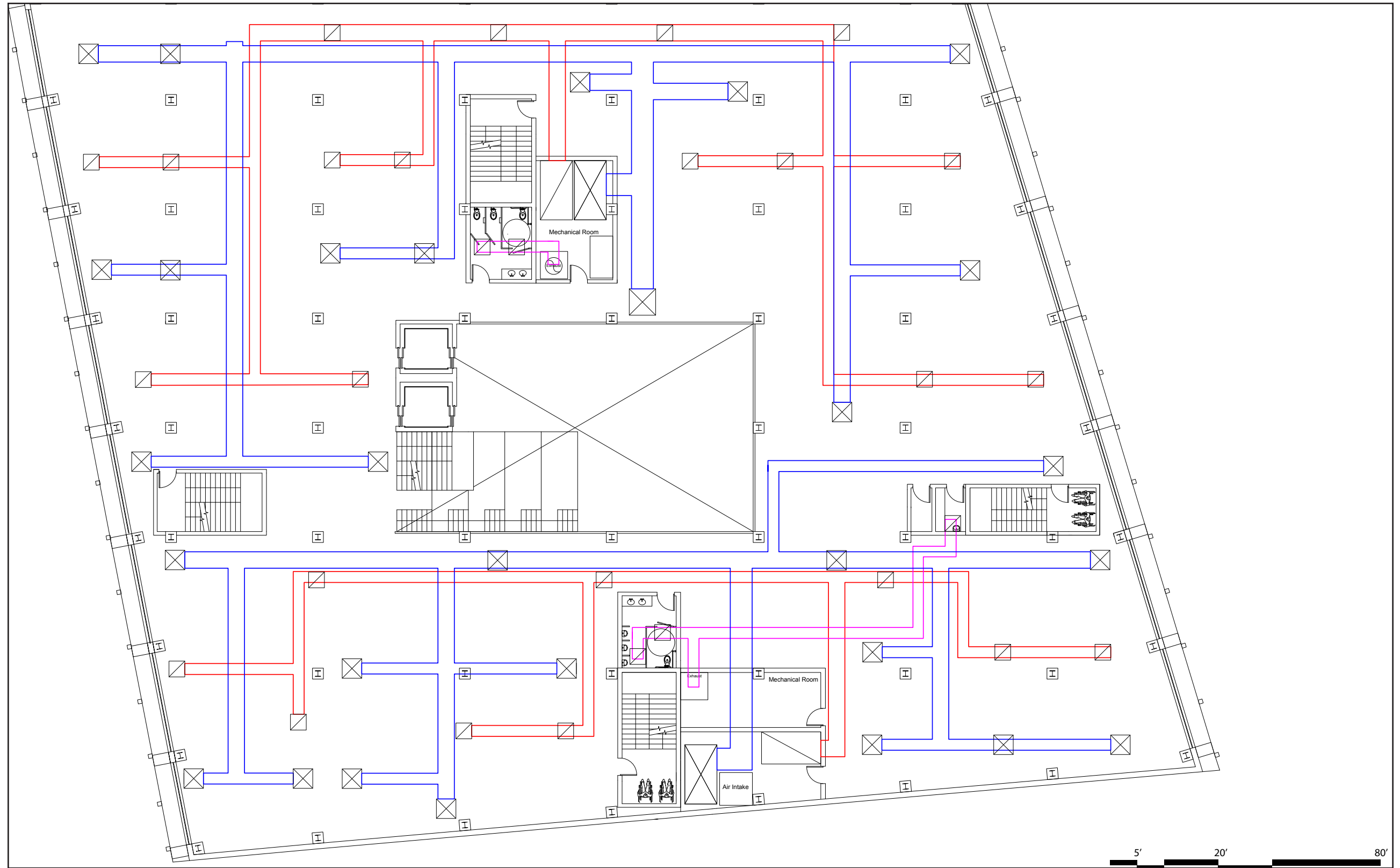

**2016 INTEGRATED BUILDING SYSTEMS**  
**ARCH 2178**  
 Hyunbae Chang | Marco Didonet |  
 Iris Kim | Jiseon Park | Natasha Ruiz

**FilterScape**  
**Commercial Building**  
 117 Wickenden Street, Providence RI 02903

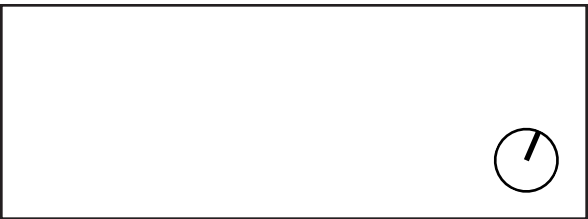

**MECHANICAL**  
 HVAC Drawing | Upper Floors  
**M103**

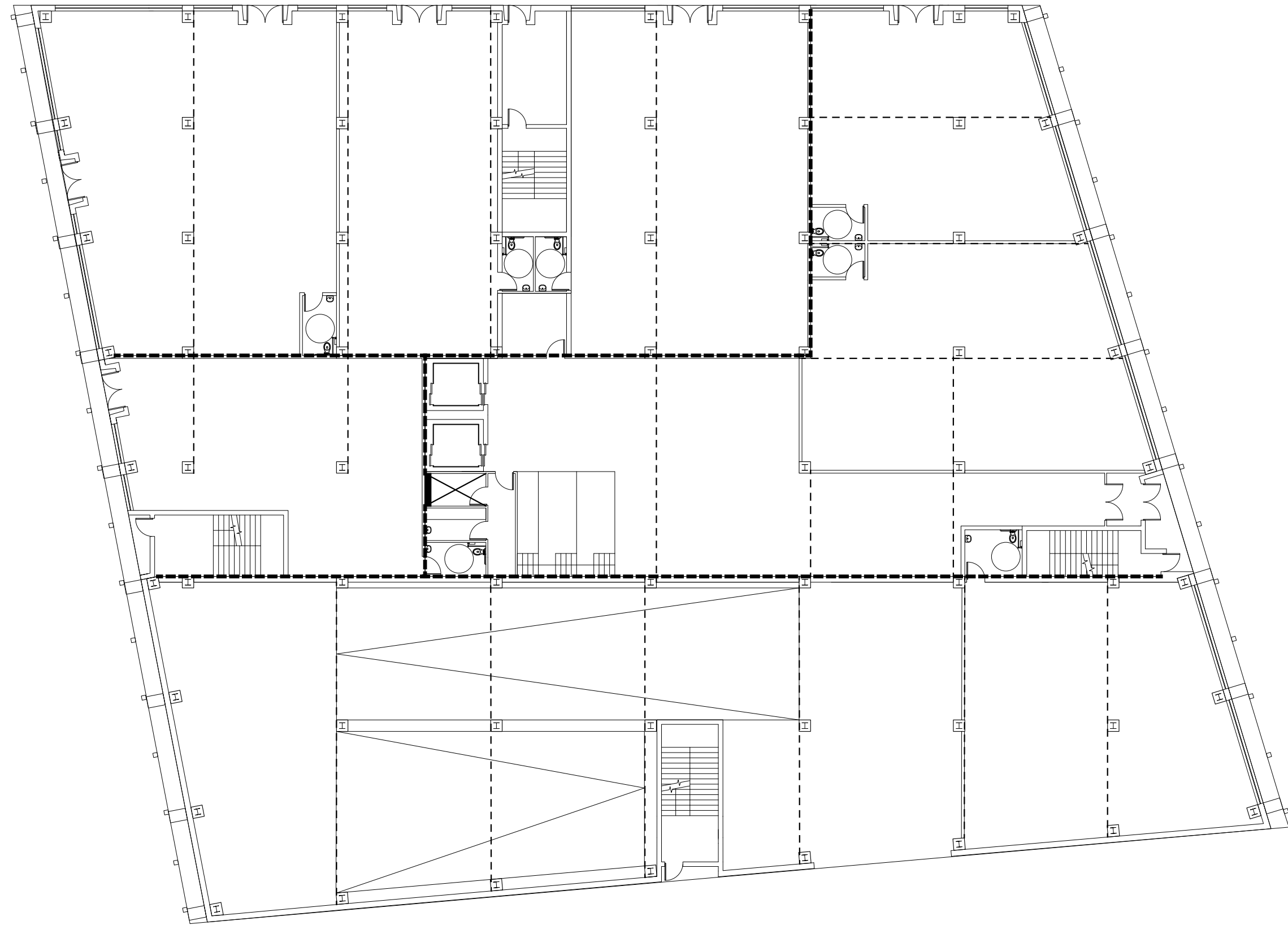

2016 INTEGRATED BUILDING SYSTEMS  
 ARCH 2178  
 Hyunbae Chang | Marco Didonet |  
 Iris Kim | Jiseon Park | Natasha Ruiz

**FilterScape**  
 Commercial Building  
 117 Wickenden Street, Providence RI 02903



**ELECTRICAL**  
 Ground Floor Plan

**E100**

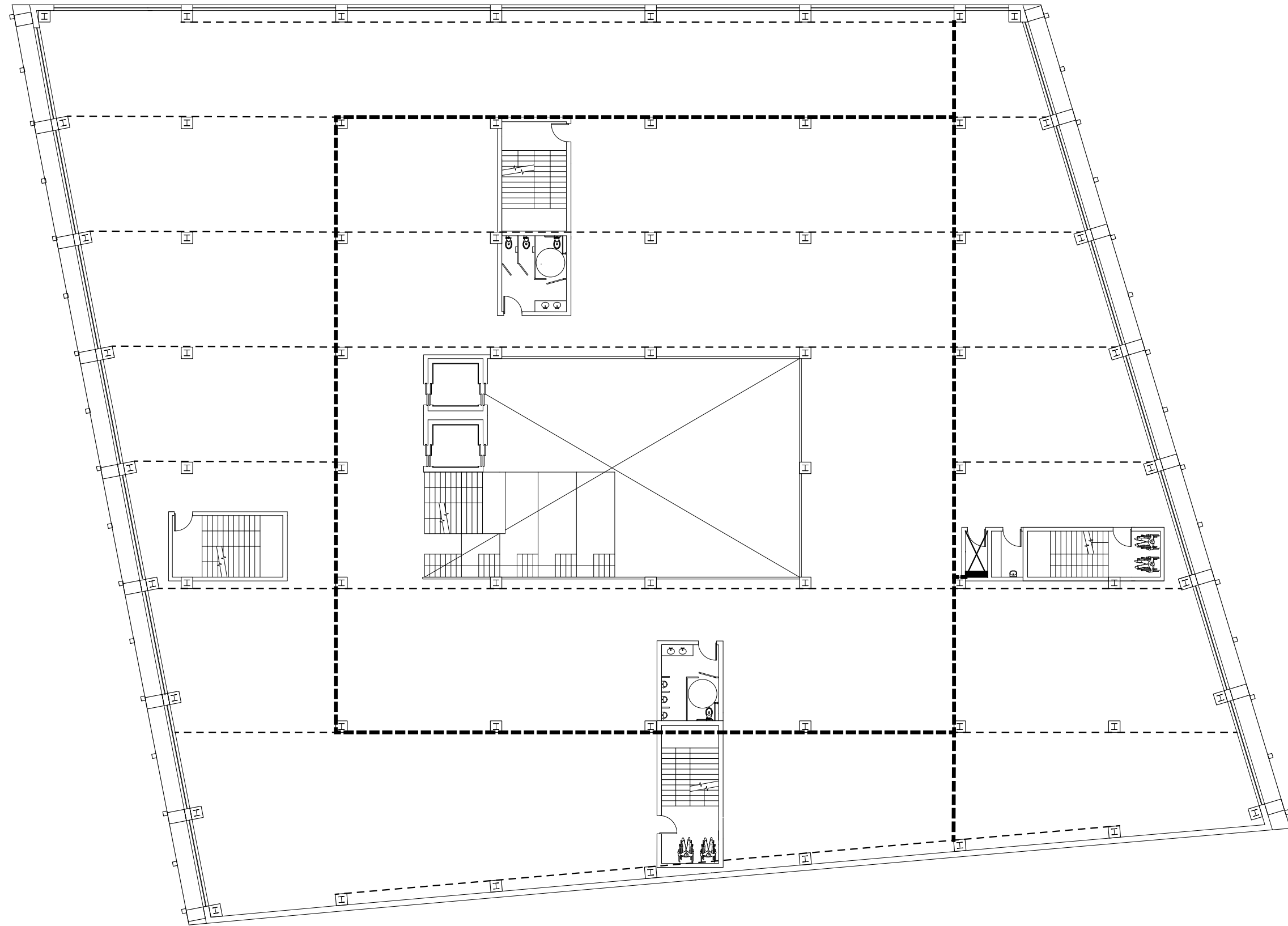

2016 INTEGRATED BUILDING SYSTEMS  
 ARCH 2178  
 Hyunbae Chang | Marco Didonet |  
 Iris Kim | Jiseon Park | Natasha Ruiz

**FilterScape**  
 Commercial Building  
 117 Wickenden Street, Providence RI 02903



**ELECTRICAL**  
 Upper Floor Plan

E101

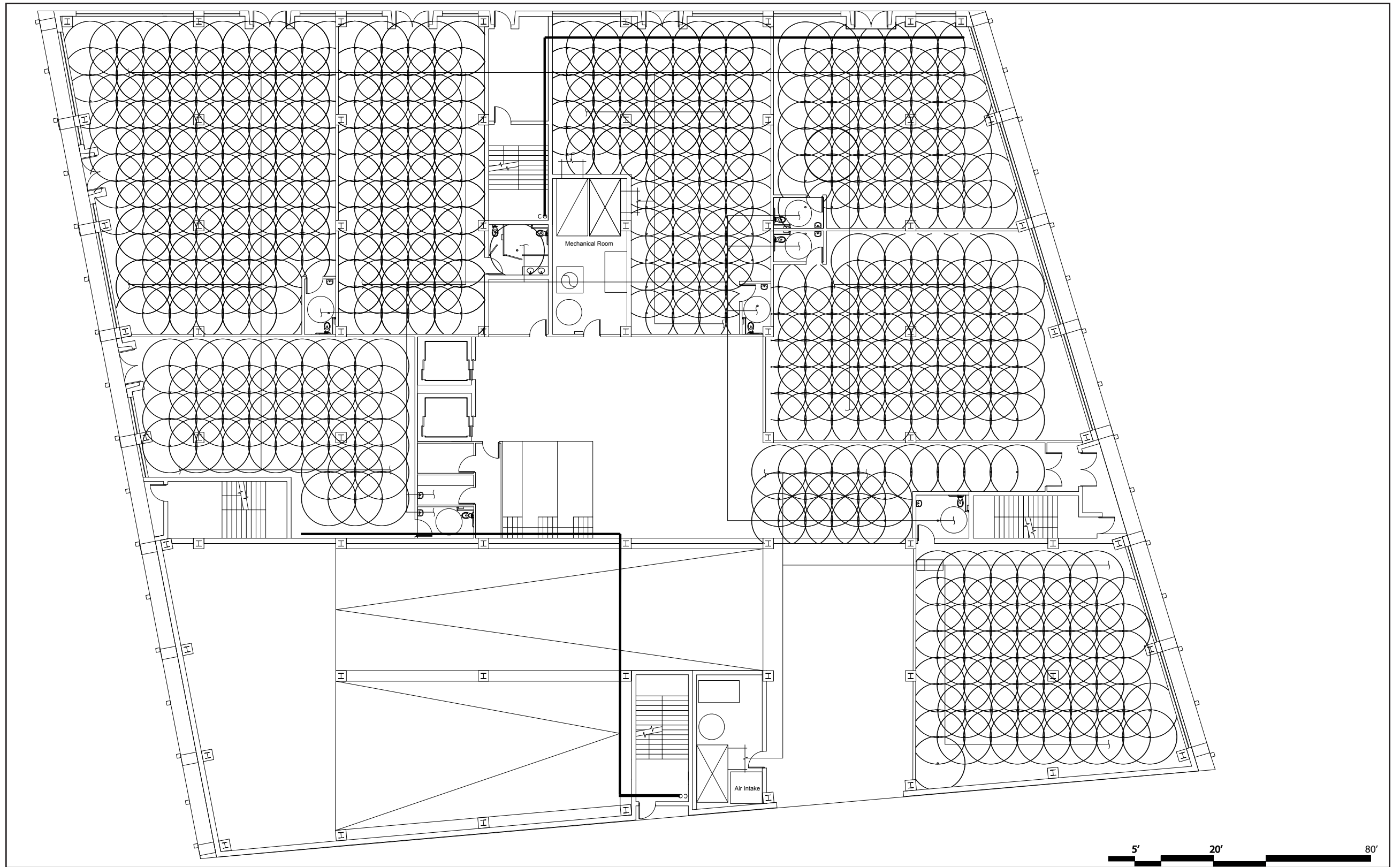

**2016 INTEGRATED BUILDING SYSTEMS**  
**ARCH 2178**  
 Hyunbae Chang | Marco Didonet |  
 Iris Kim | Jiseon Park | Natasha Ruiz

**FilterScape**  
**Commercial Building**  
 117 Wickenden Street, Providence RI 02903



**PLUMBING**  
 Ground Floor Plan

**P100**

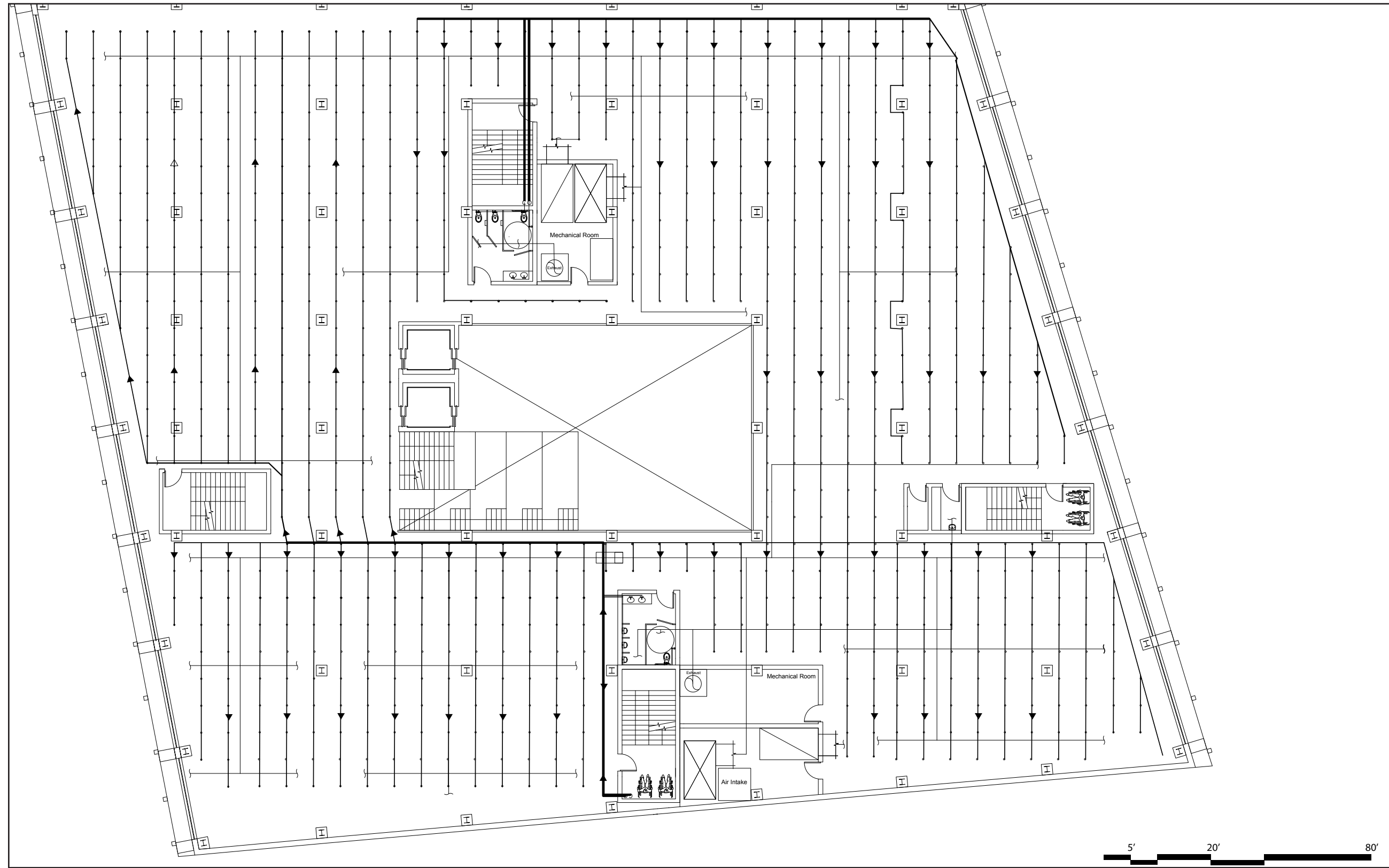

**2016 INTEGRATED BUILDING SYSTEMS**  
**ARCH 2178**  
 Hyunbae Chang | Marco Didonet |  
 Iris Kim | Jiseon Park | Natasha Ruiz

**FilterScape**  
**Commercial Building**  
 117 Wickenden Street, Providence RI 02903

**PLUMBING**  
 Upper Floor Plan



**P101**